

Last saved on 06/01/2018 2:00 PM

**TUESDAY, JUNE 5, 2018**  
**CITY COUNCIL AGENDA**  
**6:00 PM**

- I. Call to Order.
- II. Pledge of Allegiance/Invocation (Councilman Ledford).
- III. Minute Approval.
- IV. Special Presentation.

V. **Ordinances – Final Reading:**

**ECONOMIC AND COMMUNITY DEVELOPMENT**

- a. [An ordinance amending Ordinance No. 13213, known as “the Fiscal Year 2017-2018 Budget Ordinance” so as to reallocate \\$15,000.00 from General Funds to Family Promise to meet the emergency housing needs of displaced individuals experiencing homelessness and shelter needs for veterans in its program.](#)

**FINANCE**

- b. [An ordinance to amend Chattanooga City Code, Part II, Chapter 2, Section 2-400 through 2-404; 2-406 through 2-409; 2-411; 2-419; 2-420; and 2-422, relative to the Fire and Police Pension Fund.](#)

VI. **Ordinances – First Reading:**

**YOUTH AND FAMILY DEVELOPMENT**

- a. [An ordinance amending Chattanooga City Code, Part II, Chapter 26, Sections 26-26, 26-27, 26-34, and 26-35, relative to fee changes. \(Deferred from 5/29/18\)](#)

VII. **Resolutions:**

**ECONOMIC AND COMMUNITY DEVELOPMENT**

- a. [A resolution authorizing the Administrator for the Department of Economic and Community Development to accept, if awarded, the 2018 Building Better Communities Grant, sponsored by the American Water Charitable Foundation and the National Recreation and Park Association, to be applied to the East Lake Park Project, in the amount of \\$150,000.00.](#)

## Agenda for Tuesday, June 5, 2018

### Page 2

- b. [A resolution authorizing the Administrator for the Department of Economic and Community Development to accept and distribute for Fiscal Years 2013-2019 the Community Development Block Grant \(CDBG\), HOME Investment Partnership Act Funds \(HOME\), and Emergency Solutions Grant \(ESG\) Funds from the U.S. Department of Housing and Urban Development \(HUD\) and Program Income, for a total approximate amount of \\$3,438,143.00.](#)

### **FIRE**

- c. [A resolution authorizing the donation of a 1999 Thomas 77 Passenger School Bus to the Erlanger's Center for Emergency and Disaster Medicine Services to utilize on mass fatality incidents or mass hospital evacuations, with an approximate value of \\$100,549.88.](#)

### **HUMAN RESOURCES**

- d. [A resolution authorizing the appointment of Phillip McKenzie, as a special police officer \(unarmed\) for the McKamey Animal Center, to do special duty as prescribed herein, subject to certain conditions.](#)
- e. [A resolution authorizing the appointment of Welford M. Sydnor, Jr., as a special police officer \(unarmed\) for the Land Development Office, do so special duty as prescribed herein, subject to certain conditions.](#)
- f. [A resolution authorizing the appointment of John Harris, as a special police officer \(unarmed\) for the Department of Economic and Community Development, do so special duty as prescribed herein, subject to certain conditions.](#)
- g. [A resolution authorizing the appointment of Joshua Chandler, as a special police officer \(unarmed\) for the Department of Economic and Community Development, do so special duty as prescribed herein, subject to certain conditions.](#)
- h. [A resolution authorizing Collins and Company to pay an on-the-job injury settlement to City Employee, Dennis Pedigo \(Employee ID# 60441\), in the amount of \\$49,338.86 for a permanent partial impairment rating in accordance with the City's injury on duty policy.](#)

### **IT**

- i. [A resolution authorizing the Chief Information Officer to renew a contract with AST Corporation as the provider of Hosting and Professional Services for Oracle E Business Suite SLA and other technical services to the Department of Information Technology for the period of one \(1\) year beginning May 28, 2018 through May 27, 2019, with the option to extend for one \(1\) additional year, for an amount not to exceed \\$1 million per contract year.](#)

- j. [A resolution authorizing the Chief Information Officer to renew a blanket contract with BG Staffing \(Zycron Information Technology Services and Solutions\) as provider of professional services for the Department of Information Technology, for the period of one \(1\) year beginning May 28, 2018 through May 27, 2019, for an amount not to exceed \\$1 million per contract year.](#)

**POLICE**

- k. [A resolution authorizing the retirement of K-9 Duco as a service dog. \(Deferred from 5/29/18\)](#)

**PUBLIC WORKS AND TRANSPORTATION**

**Public Works**

- l. [A resolution authorizing the Administrator for the Department of Public Works to enter into a Third Agreement to Exercise Option to Renew for the Partnership Agreement with Chattanooga Flying Disc Club, for the renewal term of one \(1\) year for the continued use and operation of all present and future disc golf courses at City public parks and for daily use and tournament play.](#)

VIII. Purchases.

IX. Other Business.

**a. Approval of renewal certifications for grocery stores wishing to sell wine:**

1. Publix Tennessee, LLC #1460, [400 N. Market Street](#) (District 2)
2. Publix Tennessee, LLC #1166, [5928 Hixson Pike, Suite 112](#) (District 3)
3. Publix Tennessee, LLC #1165, [8644 E. Brainerd Road](#) (District 4)
4. Publix Tennessee, LLC #1244, [5958 Snow Hill Road, Suite 168](#) (District 6)

X. Committee Reports.

XI. Recognition of Persons Wishing to Address the Council on Non-Agenda Matters.

XII. Adjournment.

**TUESDAY, JUNE 12, 2018**  
**CITY COUNCIL AGENDA**  
**6:00 PM**

1. Call to Order.
2. Pledge of Allegiance/Invocation (Councilman Gilbert).
3. Minute Approval.
4. Special Presentation.

***“Navy Week Proclamation”***

By Vice-Chairman Erskine Oglesby

5. **PUBLIC HEARING ON FY19 BUDGET.**
6. **Ordinances – Final Reading:**

**YOUTH AND FAMILY DEVELOPMENT**

- a. [An ordinance amending Chattanooga City Code, Part II, Chapter 26, Sections 26-26, 26-27, 26-34, and 26-35, relative to fee changes.](#)

7. **Ordinances – First Reading:**

**PLANNING**

- a. [2018-075 Hillocks Farm Land Company, LLC c/o Duane Horton \(Amend Conditions\). An ordinance to amend Chattanooga City Code, Part II, Chapter 38, Zoning Ordinance, so as to amend Condition 2.1 of specific conditions for R-4 Zoning Ordinance No. 12809 of previous Case No. 2014-008 on part of property located at 6100 Highway 153, more particularly described herein, subject to certain conditions. \(District 1\) \(Recommended for approval by Planning and recommended for denial as to Applicant’s request\) \(Deferred from 5/8/18\)](#)

[2018-075 Hillocks Farm Land Company, LLC c/o Duane Horton \(Amend Conditions\). An ordinance to amend Chattanooga City Code, Part II, Chapter 38, Zoning Ordinance, so as to amend Condition 2.1 of specific conditions for R-4 Zoning Ordinance No. 12809 of previous Case No. 2014-008 on part of property located at 6100 Highway 153, more particularly described herein, subject to certain conditions. \(Staff Version\)](#)



**Agenda for Tuesday, June 5, 2018**

**Page 5**

- b. 2018-077 Hillocks Farm Land Company, LLC c/o Duane Horton (R-1 Residential Zone to C-2 Convenience Commercial Zone). An ordinance to amend Chattanooga City Code, Part II, Chapter 38, Zoning Ordinance, so as to rezone property located at 6048 Highway 153, more particularly described herein, from R-1 Residential Zone to C-2 Convenience Commercial Zone. (District 1) (Recommended for approval by Planning) (Deferred from 5/8/18)

2018-077 Hillocks Farm Land Company, LLC c/o Duane Horton (R-1 Residential Zone to C-2 Convenience Commercial Zone). An ordinance to amend Chattanooga City Code, Part II, Chapter 38, Zoning Ordinance, so as to rezone property located at 6048 Highway 153, more particularly described herein, from R-1 Residential Zone to C-2 Convenience Commercial Zone, subject to certain conditions. (Staff Version)

- c. 2018-078 Hillocks Farm Land Company, LLC c/o Duane Horton (R-1 Residential Zone to C-2 Convenience Commercial Zone). An ordinance to amend Chattanooga City Code, Part II, Chapter 38, Zoning Ordinance, so as to rezone property located at 6046 Highway 153, more particularly described herein, from R-1 Residential Zone to C-2 Convenience Commercial Zone. (District 1) (Recommended for approval by Planning) (Deferred from 5/8/18)

2018-078 Hillocks Farm Land Company, LLC c/o Duane Horton (R-1 Residential Zone to C-2 Convenience Commercial Zone). An ordinance to amend Chattanooga City Code, Part II, Chapter 38, Zoning Ordinance, so as to rezone property located at 6046 Highway 153, more particularly described herein, from R-1 Residential Zone to C-2 Convenience Commercial Zone, subject to certain conditions. (Staff Version)

- d. 2018-079 Hillocks Farm Land Company, LLC c/o Duane Horton (R-1 Residential Zone to C-2 Convenience Commercial Zone). An ordinance to amend Chattanooga City Code, Part II, Chapter 38, Zoning Ordinance, so as to rezone property located at 6100 Highway 153, more particularly described herein, from C-2 Convenience Commercial Zone to R-4 Special Zone, subject to certain conditions. (District 1) (Recommended for approval by Planning and Staff) (Deferred from 5/8/18)

- e. 2018-052 John Jernigan, Jr. (R-1 Residential Zone to RZ-1 Zero Lot Line Residential Zone). An ordinance to amend Chattanooga City Code, Part II, Chapter 38, Zoning Ordinance, so as to rezone property located at 512 Tucker Street, more particularly described herein, from R-1 Residential Zone to RZ-1 Zero Lot Line Residential Zone. (District 2) (Recommended for approval by Planning and recommended for denial by Staff) (Deferred from 5/15/2018)

- f. [2018-056 John Jernigan, Jr. \(R-1 Residential Zone to RZ-1 Zero Lot Line Residential Zone\). An ordinance to amend Chattanooga City Code, Part II, Chapter 38, Zoning Ordinance, so as to rezone property located at 510 Tucker Street, more particularly described herein, from R-1 Residential Zone to RZ-1 Zero Lot Line Residential Zone. \(District 2\) \(Recommended for approval by Planning and recommended for denial by Staff\) \(Deferred from 5/15/2018\)](#)
- g. [2018-093 Riverton Development Group, LLC \(R-1 Residential Zone and M-1 Manufacturing Zone to R-1 Residential Zone, R-4 Special Zone, and UGC Urban General Commercial Zone\). An ordinance to amend Chattanooga City Code, Part II, Chapter 38, Zoning Ordinance, so as to rezone part of property located at 1100 Lupton Drive, more particularly described herein, from R-1 Residential Zone and M-1 Manufacturing Zone to R-1 Residential Zone, R-4 Special Zone, and UGC Urban General Commercial Zone, subject to certain conditions. \(District 2\) \(Recommended for approval by Planning and recommended for denial of R-4 by Staff\)](#)
- [2018-093 Riverton Development Group, LLC \(R-1 Residential Zone and M-1 Manufacturing Zone to R-1 Residential Zone and UGC Urban General Commercial Zone\). An ordinance to amend Chattanooga City Code, Part II, Chapter 38, Zoning Ordinance, so as to rezone part of property located at 1100 Lupton Drive, more particularly described herein, from R-1 Residential Zone and M-1 Manufacturing Zone to R-1 Residential Zone and UGC Urban General Commercial Zone, subject to certain conditions. \(Staff Version\)](#)
- [2018-093 Riverton Development Group, LLC \(R-1 Residential Zone and M-1 Manufacturing Zone to R-1 Residential Zone, R-4 Special Zone, and UGC Urban General Commercial Zone\). An ordinance to amend Chattanooga City Code, Part II, Chapter 38, Zoning Ordinance, so as to rezone part of property located at 1100 Lupton Drive, more particularly described herein, from R-1 Residential Zone and M-1 Manufacturing Zone to R-1 Residential Zone, R-4 Special Zone, and UGC Urban General Commercial Zone. \(Applicant Version\)](#)
- h. [2018-082 Holcomb Family Partners c/o Tim Holcomb \(R-3 Residential Zone to C-2 Convenience Commercial Zone\). An ordinance to amend Chattanooga City Code, Part II, Chapter 38, Zoning Ordinance, so as to rezone part of property located at 5513 Highway 153, more particularly described herein, from R-3 Residential Zone to C-2 Convenience Commercial Zone. \(District 3\) \(Recommended for approval by Planning and Staff\)](#)
- i. [2018-084 Vanessa E. Moser \(R-1 Residential Zone to A-1 Urban Agricultural Zone\). An ordinance to amend Chattanooga City Code, Part II, Chapter 38, Zoning Ordinance, so as to rezone property located at 1649 Kamin Road, more particularly described herein, from R-1 Residential Zone to A-1 Urban Agricultural Zone. \(District 3\) \(Recommended for approval by Planning and Staff\)](#)

- j. 2018-058 Cynthia Brown (R-1 Residential Zone to R-4 Special Zone). An ordinance to amend Chattanooga City Code, Part II, Chapter 38, Zoning Ordinance, so as to rezone property located at 7724 Standifer Gap Road, more particularly described herein, from R-1 Residential Zone to R-4 Special Zone, subject to certain conditions. **(District 4) (Recommended for approval by Planning and recommended for denial by Staff)**

2018-058 Cynthia Brown (R-1 Residential Zone to O-1 Office Zone). An ordinance to amend Chattanooga City Code, Part II, Chapter 38, Zoning Ordinance, so as to rezone property located at 7724 Standifer Gap Road, more particularly described herein, from R-1 Residential Zone to O-1 Office Zone. **(Applicant Version)**

- k. 2018-083 Tom Willumson (O-1 Office Zone to R-1 Residential Zone). An ordinance to amend Chattanooga City Code, Part II, Chapter 38, Zoning Ordinance, so as to rezone property located at 3951 Cromwell Road, more particularly described herein, from O-1 Office Zone to R-1 Residential Zone. **(District 5) (Recommended for approval by Planning and recommended for denial of R-1 and approval to lift all conditions by Staff)**

- l. 2018-081 Marvina Baksh (Lift Conditions). An ordinance to amend Chattanooga City Code, Part II, Chapter 38, Zoning Ordinance, so as to lift Condition No. 5 of Ordinance No. 13132 from previous Case No. 2016-165 from property located at 6684 East Brainerd Road, more particularly described herein, subject to certain conditions. **(District 6) (Recommended for approval by Planning)**

2018-081 Marvina Baksh (Lift Conditions). An ordinance to amend Chattanooga City Code, Part II, Chapter 38, Zoning Ordinance, so as to lift Condition No. 5 of Ordinance No. 13132 from previous Case No. 2016-165 from property located at 6684 East Brainerd Road, more particularly described herein, subject to certain conditions. **(Staff Version)**

2018-081 Marvina Baksh (Lift Conditions). An ordinance to amend Chattanooga City Code, Part II, Chapter 38, Zoning Ordinance, so as to lift Condition No. 5 of Ordinance No. 13132 from previous Case No. 2016-165 from property located at 6684 East Brainerd Road, more particularly described herein. **(Applicant Version)**

- m. 2018-090 Silverdale Baptist Church c/o Doug Anderson (R-1 Residential Zone to C-2 Convenience Commercial Zone). An ordinance to amend Chattanooga City Code, Part II, Chapter 38, Zoning Ordinance, so as to rezone property located at 2916 Silverdale Road, more particularly described herein, from R-1 Residential Zone to C-2 Convenience Commercial Zone, subject to certain conditions. **(District 6) (Recommended for approval by Planning)**

2018-090 Silverdale Baptist Church c/o Doug Anderson (R-1 Residential Zone to C-2 Convenience Commercial Zone). An ordinance to amend Chattanooga City Code, Part II, Chapter 38, Zoning Ordinance, so as to rezone property located at 2916 Silverdale Road, more particularly described herein, from R-1 Residential Zone to C-2 Convenience Commercial Zone, subject to certain conditions. (Staff Version)

2018-090 Silverdale Baptist Church c/o Doug Anderson (R-1 Residential Zone to C-2 Convenience Commercial Zone). An ordinance to amend Chattanooga City Code, Part II, Chapter 38, Zoning Ordinance, so as to rezone property located at 2916 Silverdale Road, more particularly described herein, from R-1 Residential Zone to C-2 Convenience Commercial Zone. (Applicant Version)

- n. 2018-087 Dexter White (M-1 Manufacturing Zone to UGC Urban General Commercial Zone). An ordinance to amend Chattanooga City Code, Part II, Chapter 38, Zoning Ordinance, so as to rezone property located at 432 West 24<sup>th</sup> Street, more particularly described herein, from M-1 Manufacturing Zone to UGC Urban General Commercial Zone. (District 7) (Recommended for approval by Planning and Staff)
- o. An ordinance to amend Chattanooga City Code, Part II, Chapter 38, Zoning Ordinance, Article VI, Section 38-504, Height and Area Exceptions and Other Special Exceptions to clarify interior side setbacks for detached small storage building, private automobile storage garages, private shops for woodworking, metal working, ceramic, etc., and other similar accessory buildings located in the R-T/Z Residential Townhouse Zero Lot Line Zone.

8. **Resolutions:**

**ECONOMIC AND COMMUNITY DEVELOPMENT**

- a. A resolution authorizing the Mayor to execute a Full Satisfaction and Release of Right of Reversion to Quitclaim Deed, in substantially the form attached, for the release and discharge of the Right of Reversion for properties located on Reggie White Boulevard, from the City of Chattanooga to Cornerstones, Inc. (District 7)

**FINANCE**

- b. A resolution authorizing the City Treasurer to award commercial and general banking services to First Tennessee Bank, including lockbox services, payroll cards, safekeeping and custodial accounts, and for the collection of sewer fees, property taxes, and water quality fees at branch locations, for a one (1) year contract with two (2) possible one (1) year renewals by mutual agreement, in the amount of \$52,000.00.
- c. A resolution authorizing the City Treasurer to award commercial and general banking services to SunTrust Bank, including merchant card services, purchasing cards, safekeeping and custodial accounts, for a one (1) year contract with two (2) possible one (1) year renewals by mutual agreement, in the amount of \$240,000.00.

**INFORMATION TECHNOLOGY**

- d. A resolution authorizing the Chief Information Officer to renew the blanket contract with TriTech Software Systems as providers of software interface technologies, support, and other related expenses for citywide software integration for a period of one (1) year beginning July 1, 2018 through June 30, 2019, with the option to extend for one (1) additional year, for an amount not to exceed \$500,000.00 per contract year.

**PLANNING**

- e. 2018-091 Hillocks Farm Land Company, LLC c/o Duane Horton (Special Exceptions Permit). A resolution authorizing a Special Exceptions Permit for a Residential Planned Unit Development for a part of property located at 6100 Highway 153. (District 1) (Recommended for approval by Planning and Staff)
- f. 2018-089 John and Eileen Thornton (Special Exceptions Permit). A resolution authorizing a Special Exceptions Permit for a Residential Planned Unit Development on two properties located in the Unit Block of Rivervista Drive, subject to certain conditions. (District 2) (Recommended for approval by Planning)

2018-089 John and Eileen Thornton (Special Exceptions Permit). A resolution authorizing a Special Exceptions Permit for a Residential Planned Unit Development on two properties located in the Unit Block of Rivervista Drive, subject to certain conditions. (Staff Version)

2018-089 John and Eileen Thornton (Special Exceptions Permit). A resolution authorizing a Special Exceptions Permit for a Residential Planned Unit Development on two properties located in the Unit Block of Rivervista Drive. (Applicant Version)

- g. 2018-094 Riverton Development Group, LLC (Special Exceptions Permit). A resolution authorizing a Special Exceptions Permit for a Residential Planned Unit Development on property located at 1100 Lupton Drive, subject to certain conditions. (District 2) (Recommended for approval by Planning and Staff)

2018-094 Riverton Development Group, LLC (Special Exceptions Permit). A resolution authorizing a Special Exceptions Permit for a Residential Planned Unit Development on property located at 1100 Lupton Drive. (Applicant Version)

**PUBLIC WORKS AND TRANSPORTATION**

**Public Works**

- h. A resolution authorizing the award of Contract No. Y-18-015-201 to JDH Company, Inc., Replacement Roofing System for East Chattanooga YFD Center Building, in the amount of \$175,352.00, with a contingency amount of \$17,500.00, for an amount not to exceed \$192,852.00.

## Agenda for Tuesday, June 5, 2018

### Page 10

- i. [A resolution authorizing the approval of Change Order No. 1 \(Final\) for Tower Construction Company of Chattanooga, TN, relative to Contract No. Y-16-014-201, Multiple Playgrounds and Pavilions Project, for an increased amount of \\$14,287.23, for a revised contract amount of \\$139,009.40.](#)
  - j. [A resolution authorizing the Mayor to execute an agreement with Hamilton County relative to the Courts Community Service Program for Fiscal Year 2018-2019, for an amount not to exceed \\$60,000.00.](#)
  - k. [A resolution authorizing the approval of Change Order No. 1 for Jacobs Engineering Group relative to Contract No. W-17-006-101, Program Management for Consent Decree Implementation, a Consent Decree Project, for the renewal for year two \(2\) of the five \(5\) year program, in the amount of \\$2,068,090.00, for the revised contract amount of \\$4,066,513.00. \(Consent Decree\)](#)
9. Purchases.
  10. Other Business.
  11. Committee Reports.
  12. Recognition of Persons Wishing to Address the Council on Non-Agenda Matters.
  13. Adjournment.

Proposed City Council Purchases 6-5-18

DEPARTMENT REQUISITION NO.	ITEM DESCRIPTION	BIDS REQUESTED	BIDS RETURNED	LOWEST/BEST BIDDER	COST	FUND NAME	NOTES
R169392 Public Works	New Blanket Contract for Ladder Climbing Safety Equipment- Waste Resource Division	15	5	Airgas, LLC 700 Manufacturers Row Chattanooga, TN 37421	Estimated \$200,000 Annually	Interceptor Sewer Operations	New Blanket Contract for Ladder Climbing Safety Equipment- Waste Resources Division. The new contract will be a period of twelve (12) months with two (2) renewal options. There were 15 direct bid solicitations and we received 5 responses in the publicly advertised bid proceedings. Airgas, LLC was the lowest bid meeting specifications.
R168101 Public Works	New Blanket Contract for Manhole Rehabilitation-Waste Resources Division	9	1	Video Industrial Services, Inc. 7721 2nd Avenue North Avenue Birmingham, AL 35206	Estimated \$250,000 Annually	Interceptor Sewer Operations	New Blanket Contract for Manhole Rehabilitation-Waste Resources Division. The new contract will be a period of twelve (12) months with two (2) renewal options. There were 9 direct bid solicitations and we received 1 response in the publicly advertised bid proceedings. After reposting, Video Industrial Services, Inc. was the only bid meeting specifications.
R170981 Public Works	Purchase of one (1) 1.5 MW Portable Generator- Waste Resource Division	-	-	Stowers Machinery Corporation 4066 S. Access Road Chattanooga, TN 37406	\$462,290.00	Interceptor Sewer Operations	Purchase of one (1) 1.5 M MW Portable Generator-Waste Resources Division. This purchase utilizes the NJPA contract Contact No. 120617. TCA 6-56-304-2 allows for this single source purchase exempted from usual advertising and bidding requirements.
R167759 Public Works	Purchase of Sewer Pipes & Fittings- Waste Resources Division	8	4	Piping Supply Company 3008 N. Hickory Street Chattanooga, TN 37406	\$407,280.92	Interceptor Sewer Operations	Purchase of Sewer Pipes & Fittings-Waste Resources Division. There were 8 direct bid solicitations and we received 4 responses in the publicly advertised bid proceedings. Piping Supply Co. was the lowest bid meeting specifications.
R168001 Public Works	Purchase of two (2) Nidec Motors- Waste Resources Division	8	4	Rome Electric Motor Works Inc. 36 Westside Industrial Blvd. Rome, GA 30165	\$139,960.00	Interceptor Sewer Operations	Purchase of two (2) Nidec Motors-Waste Resources Division. There were 8 direct bid solicitations and we received 4 responses in the publicly advertised bid proceedings. Rome Electric Motor Works, Inc. was the lowest bid meeting specifications.
R168786 Public Works	Purchase of one (1) Isuzu Cab & Chassis-Fleet Management Division	12	3	Lee-Smith, Inc. 2600 8th Avenue Chattanooga, TN 37407	\$74,003.94	General Fund	Purchase of one (1) Isuzu Cab & Chassis- Fleet Management Division. There were 12 direct bid solicitations and we received 3 responses in the publicly advertised bid proceedings. Lee-Smith, Inc. was the best bid meeting specifications.
PO535097 Public Works	Blanket Contract Renewal for Grounds Maintenance/Enterprise Industrial Park-Division Parks	8	5	Special Touch Lawn Service 4608 Woodmore View Circle Chattanooga, TN 37411	Estimated \$35,000 Annually	General Fund	Blanket Contract Renewal of PO535097 for Grounds Maintenance/Enterprise Industrial Park- Parks Division. There were 8 direct bid solicitations and we received 5 responses in the publicly advertised bid proceedings. Special Touch Lawn Service was the best bid meeting specifications.
R167748 Public Works	Two (2) New Blanket Contracts for River Sand-City Wide Services	4	2	McKinnley Excavating 411 West 21st Street Chattanooga, TN 37408 and Ramsey Trucking, Inc. 731 Pineville Road Chattanooga, TN 37405	Total Estimated \$60,000 Annually	General Fund	New Blanket Contracts for River Sand-City Wide Services. The new contract will be a period of twelve (12) months with two (2) renewal options. There were 4 direct bid solicitations and we received 2 responses in the publicly advertised bid proceedings. McKinnley Excavating & Ramsey Trucking, Inc. were the best bids meeting specifications.
PO543612 Public Works	Blanket Contract Renewal for Comet Vehicle Tracking System-Fleet Management Division	-	-	Actsoft, Inc. 10006 N. Dale Mabry Highway, Suite 100 Tampa, FL 33618	Estimated \$125,000 Annually	General Fund	Blanket Contract Renewal of PO543612 for Comet Vehicle Tracking System-Fleet Management Division. This renewal is through May 2019. TCA 6-56-304-2 allowed for this single source purchase, exempted from usual advertising and bidding requirements.

PO544594 Transportation Department	Blanket Contract Renewal for Pedestrian Street Light Poles	3	2	Sun Valley 660 West Avenue O Palmdake, CA 93551	Estimated \$95,250 Annually	General Fund	Blanket Contract Renewal of PO544594 for Pedestrian Street Light Poles- Transportation Department. There were 3 direct bid solicitations and we received 2 responses in the publicly advertised bid proceedings. Sun Valley was the best bid meeting specifications.
PO543901 Youth & Family Development	Blanket Contract Renewal for Baby Diapers and Wipes	10	7	Diapers4Less 13460 60th Place N., Suite 110 Plymouth, MN 55446	Estimated \$135,000 Annually	General Fund	Blanket Contract Renewal for Baby Diapers and Wipes. There were 10 direct bid solicitations and we received 7 responses in the publicly advertised bid proceedings. Diapers4Less was the best bid meeting specifications.





# City of Chattanooga

Mayor Andy Berke

May 30, 2018

**Mr. Justin Holland**  
Administrator, Public Works Department  
Fleet Management Division  
1250 Market Street, Suite 2100  
Chattanooga, TN 37402

**Subject: 169392 / 305116 – Ladder Climbing Safety Equipment – Waste Resource Division –  
Public Works Department**

**Dear Mr. Holland:**

**Council approval is recommended to issue a twelve (12) month blanket contract for Ladder Climbing Safety Equipment, with the option for two (2) additional twelve (12) month terms for an estimated annual amount of \$200,000.**

**The invitation to bid was sent to fifteen (15) vendors as well as formally advertised. Bids were received from five (5) vendors as shown below. Bids are retained on file in the Purchasing Office for your review upon request.**

**Vendors**

**Walter A. Wood Supply Company  
Fall Protection Systems Corporation  
Ashley Sling, Inc**

**Northern Safety Company, Inc  
Airgas, LLC**

**I recommend awarding the blanket contract for Ladder Climbing Safety Equipment to Airgas, LLC, 700 Manufacturers Row, Chattanooga, TN 37421, as the best complete bids meeting all specifications for the City of Chattanooga.**

**Respectfully yours,**

**Bonnie Woodward  
Director of Purchasing**

**BW/mlm**

**Attachments**

Item #	Item	Walter A Wood Supply Company, Inc		Northern Safety Company, Inc		Fall Protection Systems Corporation		Airgas, LLC		Ashley Sling, Inc	
		Total Price		Total Price		Total Price		Total Price		Total Price	
1	40 Foot Galvanized Kit, Miller GG0040	\$ 6,115.80		\$ 6,250.00		\$ 7,389.50		\$ 5,435.90		\$ 7,670.70	
2	40 Foot Aluminum Kit, Miller GA0040	\$ 8,762.30		\$ 9,000.00		\$ 10,586.30		\$ 7,788.20		\$ 10,990.10	
3	40 Foot Stainless steel Kit, Miller GS0040	\$ 20,829.90		\$ 21,250.00		\$ 25,168.10		\$ 18,514.50		\$ 26,126.00	
4	20 Foot Galvanized Kit, Miller GG0020	\$ 3,499.50		\$ 3,600.00		\$ 4,228.30		\$ 3,110.50		\$ 4,389.30	
5	20 Foot Aluminum Kit, Miller GA0020	\$ 4,931.30		\$ 5,000.00		\$ 5,958.30		\$ 4,383.10		\$ 6,185.10	
6	20 Foot Stainless Steel Kit, Miller GS0020	\$ 11,123.60		\$ 11,350.00		\$ 13,440.20		\$ 9,887.20		\$ 13,951.90	
7	10 Foot Aluminum Vertical Rail, Miller 15729	\$ 1,438.50		\$ 1,500.00		\$ 1,738.10		\$ 1,278.50		\$ 18,004.30	
8	10 Foot Galvanized Vertical Rail, Miller 14622	\$ 1,015.30		\$ 1,050.00		\$ 1,226.80		\$ 902.40		\$ 1,273.40	
9	10 Foot Stainless Steel Vertical Rail, Miller 16852	\$ 4,629.20		\$ 4,650.00		\$ 5,593.30		\$ 4,114.90		\$ 5,806.30	
10	Comfort GlideLoc Fall Arrestor Stainless & Aluminum, Miller 27441	\$ 4,354.90		\$ 4,350.00		\$ 5,261.80		\$ 3,871.00		\$ 5,462.10	
11	Universal II GlideLoc Fall Arrestor Stainless Steel, Miller 25805-Z7	\$ 729.41		\$ 725.00		\$ 881.32		\$ 648.33		\$ 914.87	
12	% Percentage Markup for Items not Listed		14%	-15%	40%	6%	30%				
<b>TOTAL:</b>		\$67,429.71	\$68,725.00	\$81,472.02	\$59,934.53	\$100,774.07					

**Safety Supply South LLC**  
100 Centrum Drive  
Irmo, SC 29063

**Ocoee Industrial**  
5565 N. Lee Hwy  
Cleveland, TN 37312

**Ram Tool Construction Supply**  
2011 Curtain Pole Road  
Chattanooga, TN 37406

**Northern Safety Company, Inc**  
123 Press Road  
Church Hill, TN 37642

**Southeast Rubber & Safety**  
1600 East 27th Street  
Chattanooga, TN 37404

**Grainger**  
902 Creekside Road  
Chattanooga, TN 37406

**Airgas South**  
700 Manufacturers Road  
Chattanooga, TN 37405

**Ashley Sling Inc**  
3711 Calhoun Avenue  
Chattanooga, TN 37407

**Walter A. Wood Supply Company  
Inc**  
4509 Rossville Blvd  
Chattanooga, TN 37407

**Magid Glove & Safety  
Manufacturing Company LLC**  
1300 Naperville Drive  
Romeoville, IL 60446

**Scientific Sales, Inc**  
130 Valley Court  
Oak Ridge, TN 37830

**Graybar**  
6013 John Douglas Drive  
Chattanooga, TN 37421

**Dillon Supply Company**  
1208 East 23rd Street  
Chattanooga, TN 37408

**Tennessee Sling Center Inc**  
3010 Williams Street  
Chattanooga, TN 37410

**Fall Protection Systems**  
224 N. Hwy 67, #193  
Florissant, MO 63031

Date: May 10, 2018

Requisition No.: 169392

**PURCHASING DEPARTMENT  
101 EAST 11<sup>TH</sup> STREET  
CITY HALL  
SUITE G13  
CHATTANOOGA, TENNESSEE  
37402**

**Request for Bid (RFB) for the City of Chattanooga, Tennessee**

*Proposals will be received at 101 East 11<sup>th</sup> Street, Suite G13,  
Chattanooga, TN 37402 until 2:00 P.M., EST. on May 24, 2018*

**Requisition / Bid No.: R169392 / 305116**

**Ordering Dept.: Waste Resource Division, Public Works**

**Buyer & E-mail: Mark McKeel mmckeel@chattanooga.gov**

\*\*\*\*\*

**Items Being Purchased: Ladder Climbing Safety Equipment**

\*\*\*\*\*

**\*\*\*REQUEST FOR BIDS MUST BE RECEIVED\*\*\***

**2:00 P.M., EST on May 24, 2018**

\*\*\*\*\*

The City of Chattanooga reserves the right to reject any and/or all proposals, waive any informality in the proposals received, and to accept any proposal which in its opinion may be for the best interest of the City.

The City of Chattanooga will be non-discriminatory in the purchase of all goods and services on the basis of race, color or national origin.

The City's Standard Terms and Conditions may be found on website:  
<http://www.chattanooga.gov/purchasing/standard-terms-and-conditions>

**Note: ALL BIDS MUST BE SIGNED**

All proposals received are subject to the terms and conditions contained herein and as listed in the above referenced website. The undersigned Offeror acknowledges having received, reviewed, and agrees to be bound to these terms and conditions, unless specific written exceptions are otherwise stated.

**PLEASE PROVIDE THE FOLLOWING INFORMATION:**

**Company Name:** AIRGAS LHC

**Mailing Address:** 700 MFG. RD.

**City & Zip Code:** CHATT. TN 37421

**Phone/Toll Free No.:** 423-756-6122

**Fax No.:** 423-266-1833

**E-Mail Address:** Scott.Brockwell@airgas.com

**Contact Person:** Scott Brockwell

**Company Title:** Sales

**Signature:** Scott Brockwell

# BID SOLICITATION



**City of Chattanooga**  
 101 East 11th Street, Suite G13  
 Chattanooga, TN 37402

**BID OPENING DATE AND TIME:**  
 24-MAY-18 at 2:00 PM

**BID NUMBER: 305116**

SEALED BIDS

Mail or submit two (2) signed copies of bid form to this office in the enclosed envelope. Retain one copy for your file.

**BUYER:**  
**PHONE #:** (423) 643-7230  
**DELIVERY REQUIRED:**

**V**  
**E** RFQ  
**N**  
**D**  
**O**  
**R**

**M** City of Chattanooga  
**A** 101 East 11th Street, Suite G13  
**I** Chattanooga, TN 37402  
**L**  
**T**  
**O**

Item	Class-Item	Quantity	Unit	Unit Price	Total
------	------------	----------	------	------------	-------

Any manufacturer's names, trade names, brand names, or catalog numbers used in the specifications are for the purpose of describing and establishing general quality levels. Such references are not intended to be restrictive. Bids will be considered for any brand which meets or exceeds the quality of the specifications listed for any item.

The City of Chattanooga reserves the right to reject any and/or all bids, waive any informalities in the bids received, and to accept any bid which in its opinion may be for the best interest of the city.

The City of Chattanooga will be non-discriminatory in the purchase of all goods and services on the basis of race, color, or national origin.

\*\*\*\* NOTE \*\*\*\*  
 PLEASE PROVIDE US WITH THE FOLLOWING INFORMATION:

Company Name AIRgas LLC  
 Address 700 MEADOW  
CHATT. TN 37405  
 Phone/Toll-Free No. 423-756-6122  
 Fax No. 423-266-1833  
 eMail Address Scott.Brockwell@airgas.com  
 Contact Person's Name Scott Brockwell  
 Estimated Delivery 3-4 weeks  
 Minority-Owned Business \_\_\_\_\_ Small Business \_\_\_\_\_ Veteran \_\_\_\_\_  
 Minority Woman-Owned Business \_\_\_\_\_ Disabled Veteran \_\_\_\_\_  
 Woman-Owned Business \_\_\_\_\_

NOTE: ALL BIDS RECEIVED ARE SUBJECT TO THE TERMS AND CONDITIONS

The City is Exempt from all Federal and State Tax.  
 Bids will be received at the above mentioned address.

TERMS OF PAYMENT: Net 30  
 TELEPHONE NUMBER: 423-315-5080

ALL BIDS MUST BE SIGNED - The undersigned offers the above quoted prices under the conditions contained herein.

COMPANY: AIRgas LLC  
 SIGNATURE: Scott Brockwell  
 NAME AND TITLE: Sales

# BID SOLICITATION



**City of Chattanooga**  
 101 East 11th Street, Suite G13  
 Chattanooga, TN 37402

**BID OPENING DATE AND TIME:**  
 24-MAY-18 at 2:00 PM

**BID NUMBER: 305116**

**SEALED BIDS**

Mail or submit two (2) signed copies of bid form to this office in the enclosed envelope. Retain one copy for your file.

**BUYER:**  
**PHONE #: (423) 643-7230**  
**DELIVERY REQUIRED:**

**V  
E  
N  
D  
O  
R** RFQ

**M  
A  
I  
L  
T  
O** City of Chattanooga  
 101 East 11th Street, Suite G13  
 Chattanooga, TN 37402

Item	Class-Item	Quantity	Unit	Unit Price	Total
Requisition / Bid No.: 169392 / 305116 Ordering Dept.: Waste Resource Division, Public Works Buyer: Mark McKeel Phone No.: 423-643-7236 Items Being Purchased: Ladder Climbing Safety Equipment ATTACHMENTS: 1. Specifications (6 pages) 2. Affirmative Action Plan (2 pages) 3. Iran Divestment Act Disclosure (1 page) 4. No Contact / No Advocacy Notice (1 page) City of Chattanooga (COC) Terms and Conditions posted on Website <a href="http://www.chattanooga.gov/purchasing/standard-terms-and-conditions">http://www.chattanooga.gov/purchasing/standard-terms-and-conditions</a> If you can't download call buyer for a copy. This Shall Be A Twelve (12) Month Blanket Contract To Supply and Deliver Ladder Climbing Safety Equipment for the Waste Resource Division. The Contract Term May Be Renewed For An Additional Two (2) Twelve (12) Month Terms Under The Same Terms And Conditions By Mutual Agreement. The City Of Chattanooga And The Contractor May Bilaterally Extend The Contract By Providing Written Confirmation Of Agreement By Both Parties At Least 30 Days Prior To The Contract's Current Expiration Date Into Any Successive Term As Provided Herein. **** Vendor Shall Hold Prices Firm for First (1st) Year of Contract **** Price Escalation Clause: If as a result of a general change in prices or discounts, the Contractor has changed prices to all of its customers, the price under this contract may be adjusted accordingly. Contractor may be requested to show proof of alleged price changes prior to approval of any price adjustments. QUANTITIES ARE ESTIMATES ONLY THE CITY OF CHATTANOOGA SHALL GUARANTEE NO MINIMUM OR MAXIMUM AMOUNT PURCHASED DURING THE LIFETIME OF THE CONTRACT. *** BID MUST BE RECEIVED NO LATER THAN *** *** 2:00 PM EST ON MAY 24, 2018 *** Please Submit Bids in Duplicate Indicating Bid Number (305116) on Outside Packaging **** ALL ITEMS MUST BE QUOTED F.O.B. DESTINATION **** NOTE: ALL BIDS MUST BE SIGNED All bids received are subject to the terms and conditions contained herein and as listed in the above referenced website. The undersigned Bidder acknowledges having received, reviewed, and agrees to be bound to these terms and conditions, unless specific written exceptions are otherwise stated.					

# BID SOLICITATION



City of Chattanooga  
101 East 11th Street, Suite G13  
Chattanooga, TN 37402

**BID OPENING DATE AND TIME:**  
24-MAY-18 at 2:00 PM

**BID NUMBER:** 305116

---

**BUYER:**  
**PHONE #:** (423) 643-7230  
**DELIVERY REQUIRED:**

SEALED BIDS

Mail or submit two (2) signed copies of bid form to this office in the enclosed envelope. Retain one copy for your file.

V  
E  
N  
D  
O  
R

RFQ

M  
A  
I  
L  
T  
O

City of Chattanooga  
101 East 11th Street, Suite G13  
Chattanooga, TN 37402

Item	Class-Item	Quantity	Unit	Unit Price	Total
1	40 Foot Galvanized Kit, Miller GG0040	10	Each	<u>543.59</u>	<u>5435.90</u>
2	40 Foot Aluminum Kit, Miller GA0040	10	Each	<u>778.83</u>	<u>7788.20</u>
3	40 Foot Stainless Steel Kit, Miller GS0040	10	Each	<u>1831.45</u>	<u>18,514.50</u>
4	20 Foot Galvanized Kit, Miller GG0020	10	Each	<u>311.05</u>	<u>3110.50</u>
5	20 Foot Aluminum Kit, Miller GA0020	10	Each	<u>438.31</u>	<u>4,383.10</u>
6	20 Foot Stainless Steel Kit, Miller GS0020	10	Each	<u>988.72</u>	<u>9887.20</u>
7	10 Foot Aluminum Vertical Rail, Miller 15729	10	Each	<u>127.85</u>	<u>1,278.50</u>
8	10 Foot Galvanized Vertical Rail, Miller 14622	10	Each	<u>90.24</u>	<u>902.40</u>
9	10 Foot Stainless Steel Vertical Rail, Miller 16852	10	Each	<u>411.49</u>	<u>4,114.90</u>
10	Comfort GlideLoc Fall Arrester Stainless and Aluminum, Miller 27441	10	Each	<u>387.10</u>	<u>3871.00</u>

NOTE: ALL BIDS RECEIVED ARE SUBJECT TO THE TERMS AND CONDITIONS

ALL BIDS MUST BE SIGNED – The undersigned offers the above quoted prices under the conditions contained herein.

The City is Exempt from all Federal and State Tax.  
Bids will be received at the above mentioned address.

TERMS OF PAYMENT: \_\_\_\_\_  
TELEPHONE NUMBER: \_\_\_\_\_

COMPANY: \_\_\_\_\_  
SIGNATURE: \_\_\_\_\_  
NAME AND TITLE: \_\_\_\_\_

# BID SOLICITATION



City of Chattanooga  
101 East 11th Street, Suite G13  
Chattanooga, TN 37402

**BID OPENING DATE AND TIME:**

24-MAY-18 at 2:00 PM

**BID NUMBER:** 305116

**BUYER:**

**PHONE #:** (423) 643-7230  
**DELIVERY REQUIRED:**

**SEALED BIDS**

Mail or submit two (2) signed copies of bid form to this office in the enclosed envelope. Retain one copy for your file.

V  
E  
N  
D  
O  
R  
RFQ

M  
A  
I  
L  
T  
O  
City of Chattanooga  
101 East 11th Street, Suite G13  
Chattanooga, TN 37402

Item	Class-Item	Quantity	Unit	Unit Price	Total
11	Universal II Glideloc Fall Arrester Stainless Steel, Miller 26805-Z7	1	Each	648.33	6483.30
12	<u>6</u> % Percentage Markup for Items not Listed	10	Each	<u>6%</u>	59,934.63

**NOTE: ALL BIDS RECEIVED ARE SUBJECT TO THE TERMS AND CONDITIONS**

ALL BIDS MUST BE SIGNED – The undersigned offers the above quoted prices under the conditions contained herein.

The City is Exempt from all Federal and State Tax.  
Bids will be received at the above mentioned address.

TERMS OF PAYMENT: Net 30

TELEPHONE NUMBER: 423-315-5080

COMPANY: AIRgos LLC

SIGNATURE: Scott Brockwell

NAME AND TITLE: Sales



**SPECIFICATIONS  
FOR  
ANNUAL REQUIREMENTS CONTRACT  
TO SUPPLY  
LADDER CLIMBING SAFETY EQUIPMENT  
FOR THE  
WASTE RESOURCES DIVISION  
CITY OF CHATTANOOGA, TENNESSEE  
April 2018**

**1.0 GENERAL**

**1.1 SCOPE OF SERVICES**

The Scope of Services included in these Specifications shall be for all labor, benefits, equipment, fuel, and any other related expenses necessary to provide ladder climbing safety equipment for the WASTE RESOURCES DIVISION at various locations throughout the City of Chattanooga and Hamilton County. The WASTE RESOURCES DIVISION is located the Moccasin Bend Wastewater Treatment Plant (MBWWTP), 455 Moccasin Bend Road, Chattanooga, Tennessee 37405. Ladder climbing safety equipment shall include but not be limited to furnishing vertical height access ladder system kits that provide continuous fall protection for climbing fixed ladders.

The equipment shall be manufactured by Miller GlideLoc Vertical Height Access Ladder System Kits (or an approved equal). The units shall be designed for hands free operation for climbing and smooth operation for ascending/descending. Bids are being sought on aluminum, galvanized, and stainless steel units.

Once contract is awarded, vendor must send quote within five working days from emailed request for new orders.

Any questions or comments related to the services described in these Specifications may be directed to the City of Chattanooga Purchasing Department.

**1.2 BASIS OF BIDDING**

The Contractor shall submit one (1) bid on the City's Standard Bid Form. The Bid shall include the cost per unit for equipment shown in Table 1 in section 2.2.2 B.

The unit cost shall include any and all costs for shipping, wages, benefits, indirect costs, overhead and profit, insurance, and any other related direct or indirect cost necessary to deliver the material described herein.

***The City of Chattanooga reserves the right to reject any and/or all bids, to waive any information in Bids received, and to accept any Bid which in its opinion may be in the best interest of the city.***

**1.3 SUBMITTALS**

**1.3.1 *Bid Bond***

Not Required

**1.3.2 *Performance Bond***

None Required.

**1.4 GENERAL CONDITIONS AND INSTRUCTIONS TO BIDDERS**

The Vendor shall comply with rules and conditions found in the City of Chattanooga, Purchasing Department's "General Conditions and Instructions to Bidders" that are a part of the invitation to Bid for the equipment or services specified herein.

**1.5 LENGTH OF CONTRACT**

The Contract for services described herein shall be for a period of one (1) year beginning the effective date of the award of the Contract. The Vendor shall provide a firm rate for the first year of the Contract.

The City shall have the option of extending the Contract for four (4) additional one (1) year periods at the Vendor's unit costs.

## **2.0 SERVICES AND OTHER REQUIREMENTS**

### **2.1 GENERAL**

#### **2.1.1 *Sole Vendor***

The Vendor shall not subcontract the services or assign the contract to others without the written consent of the City of Chattanooga.

#### **2.1.2 *Compliance with Applicable Regulations***

All of the equipment provided by the Vendor shall be supplied in a good and workmanlike manner. All equipment provided shall be in compliance with all applicable statues, rules, ordinances and regulations of, but not limited to, the USEPA, TDOT, OSHA, MUTCD and any similar federal, state, and local laws or regulations applicable to the Vendor or to the services described herein.

The Vendor's personnel shall comply with all City, Waste Resources Division, and Moccasin Bend WWTP work rules and regulations when on site.

#### **2.1.4 *Failure to Provide Services and Termination of Contract***

In the event the Vendor:

- a. Fails to initiate services on the date specified or otherwise agreed to;
- b. Fails to provide all of the required documentation for his personnel, insurance, and any other documentation required by these Specifications at the specified times;
- c. After having begun services, abandons them for any reason;
- d. Suspends or refuses to continue services; or
- e. Defaults in any manner in the performance under the terms of the Contract for a period of thirty (30) days (unless the Vendor is prevented from continuing for reasons beyond its control);

The City of Chattanooga shall have the right to terminate the Contract immediately upon the written notification by the City for the reasons listed above and the City shall complete the Contract or have the services completed by another vendor in any reasonable manner at the Vendor's expense.

The City shall have the right to terminate the Contract after giving a thirty-day (30) written notice to the Vendor.

**2.2 DESCRIPTION OF CONTRACTED SERVICES**

**2.2.1 General**

A. The Vendor shall provide all equipment described herein for the Waste Resources Division.

**2.2.2 Vendor Services**

A. Vendor shall supply various quantities and sizes of ladder system kits as listed below. Kits shall come complete with GlideLoc rail, end-stop, ladder attachment brackets, and hardware.

B. Pricing shall be according to the table below:

Table 1.

Item		Miller Part No.
Price		
40 foot Galvanized kit	(GG0040)	<i>ALL SAME</i>
40 foot Aluminum kit	(GA0040)	<i>''</i>
40 foot Stainless Steel kit	(GS0040)	<i>''</i>
20 foot Galvanized kit	(GG0020)	<i>''</i>
20 foot Aluminum kit	(GA0020)	<i>''</i>
20 foot Stainless Steel kit	(GS0020)	<i>''</i>
10 foot Aluminum Vertical rail	(15729)	<i>''</i>
10 foot Galvanized Vertical rail	(14622)	<i>''</i>
10 foot Stainless Steel Vertical rail	(16852)	<i>''</i>
Comfort GlideLoc Fall Arrester Stainless and Aluminum	(27441)	<i>''</i>
Universal II GlideLoc Fall Arrester Stainless Steel	(26805-Z7)	<i>''</i>
Miscellaneous	<i>6</i> % markup over invoice	

### **3.0 EXECUTION**

#### **3.1 CONTRACT STARTING DATE**

The Contract for the full services shall begin immediately on the effective date of the award of the Contract.

#### **3.2 PAYMENT OF SERVICES**

- A. The City will make payment to the Vendor according to the City's normal policies and procedures.
- B. Before an order can be placed for routine transactions, City will request a Quote from Vendor with detailed breakdown. City may require breakdown on its own form. Once City has approved the quoted price and submits Requisition for same, it will advise Vendor of the Release Number in order to place the order. Invoices that do not reference the Release Number will not be considered complete or valid.
- C. Vendor's Invoice must list a valid E-Mail Address for billing questions and inquiries.
- D. Invoice Date is critical and Invoices must be sent to the City on the Invoice Date in order for the City's tracking system to accurately reflect the record. The Invoice Date must not precede the Ship Date or Service Date.
- E. Invoice descriptions on transaction lines must match the wording of the Purchase Order transaction lines, and reference the corresponding transaction line number of the Purchase Order. The Vendor shall not invoice the City for any item that does not correspond to a line on the Purchase Order.
- F. Items being billed on Markup line must have corresponding source Invoice, and that total and Markup breakdown must be reflected on Vendor's Invoice to the City. The Markup for items purchased on the percent Markup line, is for markup of items only. No Markup is allowed for taxes or freight charges. The taxes and freight charges will be a straight reimbursement, with no Markup.

- G. Markup will be calculated as the following example:

If the part costs vendor \$100.00,  
and the Markup on contract is 10%,  
City will reimburse Vendor \$110.00.

- H. Vendor will be responsible for collecting signature and legible name of City employee when delivering goods and/or services and must be able to produce said Proof of Delivery ("POD") upon request. The POD must contain an itemized list of goods and/or services. The POD must accompany each Department's payment packet before presenting the Invoice with all necessary backup to City's Accounts Payable Division. Including copy of POD with Invoice is encouraged and speeds payment processing time.
- I. Vendor's Invoices that are billed inaccurately, incompletely, or otherwise unprocessable are not considered valid.
- J. When sending City a Revised Invoice, it must be clearly marked "Revised." When sending City a replacement Invoice, it must reference the Invoice Number it is replacing.
- K. Invoices to the City shall reference the City Department, Release Number, Work Order Number, and the first and last name of the City employee placing the order.
- L. Accurate Invoices, with all appropriate backup documentation, shall be sent to:

City of Chattanooga  
Attn: Accounts Payable Division  
101 East 11<sup>th</sup> Street, Suite 101  
Chattanooga, TN 37402  
[acctspayable@chattanooga.gov](mailto:acctspayable@chattanooga.gov)

and copy sent to:

Moccasin Bend Wastewater Treatment Plant  
455 Moccasin Bend Road  
Chattanooga, TN 37405  
[MBacctspayable@chattanooga.gov](mailto:MBacctspayable@chattanooga.gov)



## Affirmative Action Plan

The City of Chattanooga is an equal opportunity employer and during the performance of this Contract, the Contractor agrees to abide by the equal opportunity goals of the City of Chattanooga as follows:

1. The Contractor will not discriminate against any employee or applicant for employment because of race, color, religion, sex, national origin, or handicap. The Contractor will take affirmative action to ensure that applicants are employed, and the employees are treated during employment without regard to their race, color, religion, sex, national origin, or handicap. Such action shall include, but not be limited to, the following: employment, upgrading, demotion, or transfer, recruitment or recruitment advertising, layoff or termination, rates of pay, or other forms of compensation, and selection for training, including apprenticeship. The Contractor agrees to post in conspicuous places, available to employees and applicants for employment, notices setting forth the provisions of this nondiscrimination clause.
2. The Contractor will, in all solicitations or advertisements for employees placed by or on behalf of the Contractor, state that all qualified applicants will receive consideration for employment without regard to race, color, religion, sex, national origin, or handicap.
3. The Contractor will send to each labor union or representative of workers with which he/she has a collective bargaining agreement or other contract or understanding, a notice advising the said labor union or workers' representatives of the Contractor's commitments under this section, and shall post copies of the notice in conspicuous places available to employees and applicants for employment.
4. In all construction contracts or subcontracts in excess of \$10,000 to be performed for the City of Chattanooga, any contractor and/or subcontractor is further required to file in duplicate within ten (10) days of being notified that it is the lowest responsible bidder, an affirmative action plan with the EEO Director of the City of Chattanooga. This plan shall state the Contractor's goals for minority and women utilization as a percentage of the work force on this project.
5. This Plan or any attachments thereto shall further provide a list of all employees annotated by job function, race, and sex who are expected to be utilized on this project. This plan or attachment thereto shall further describe the methods by which the Contractor or Subcontractor will utilize to make good faith efforts at providing employment opportunities for minorities and women.

During the term of this contract, the Contractor upon request of the City, will make available for inspection by the City of Chattanooga copies of payroll records, personnel documents and similar records or documents that may be used to verify the Contractor's compliance with these Equal Opportunity provisions.



6. The Contractor will include the portion of the sentence immediately preceding paragraph 1 and the provisions of paragraphs 1 through 6 in every subcontract so that such provisions will be requested of each subcontractor. The Contractor agrees to notify the City of Chattanooga of any subcontractor who refuses or fails to comply with these equal opportunity provisions. Any failure or refusal to comply with these provisions the Contractor and/or Subcontractor shall be a breach of this contract.

Scott Brockwell  
(Signature of Contractor)

Salu Airgas LLC  
(Title and Name of Construction Company)

5-30-18  
(Date)

Chapter No. 817 (HB0261/SB0377). "Iran Divestment Act" enacted.  
Vendor Disclosure and Acknowledgement

By submission of this bid, each bidder and each person signing on behalf of any bidder certifies, and in the case of a joint bid each party thereto certifies as to its own organization, under penalty of perjury, that to the best of its knowledge and belief that each bidder is not on the list created pursuant to § 12-12-106.

(SIGNED) Scott H Brockwell  
(PRINTED NAME) Scott Brockwell  
(BUSINESS NAME) Airges  
(DATE) 5-11-18

For further information, please see website:

[https://www.tn.gov/assets/entities/generalservices/cpo/attachments/List\\_of\\_persons\\_pursuant\\_to\\_Tenn.\\_Code\\_Ann.\\_12-12-106,\\_Iran\\_Divestment\\_Act-July.pdf](https://www.tn.gov/assets/entities/generalservices/cpo/attachments/List_of_persons_pursuant_to_Tenn._Code_Ann._12-12-106,_Iran_Divestment_Act-July.pdf)

**No Contact/No Advocacy**

**Notice Receipt**

City of Chattanooga  
Purchasing Division

**For Submission with Sealed Bid Solicitation Responses:**

AIRgas LLC (Vendor Agent name), states that:

(1) He/She is the owner, partner, officer, representative, or agent of \_\_\_\_\_

AIRgas LLC (Business name), the Submitter of the

attached sealed solicitation response to Solicitation # \_\_\_\_\_, and said

Business has taken notice, and will abide by the following No Contact and No Advocacy clauses:

**NO CONTACT POLICY:** After the posting of this solicitation, a potential submitter is prohibited from directly or indirectly contacting any City of Chattanooga representative concerning the subject matter of this solicitation, unless such contact is made with the Purchasing Division.

**NO ADVOCATING POLICY:** To ensure the integrity of the review and evaluation process, companies and/or individuals submitting sealed solicitation responses, as well as those persons and/or companies formally/informally representing such submitters, may not directly or indirectly lobby or advocate to any City of Chattanooga representative.

**Any business entity and/or individual that does not comply with the No Contact and No Advocating policies may be subject to the rejection or disqualification of its solicitation response from consideration.**

Submitter Signature:

Scott Brockwell

Printed Name:

SCOTT BROCKWELL

Title: Sales

Date: 5-11-18



# City of Chattanooga

Mayor Andy Berke

May 30, 2018

Mr. Justin Holland  
Administrator, Public Works Department  
Waste Resources Division  
1250 Market Street, Suite 2100  
Chattanooga, TN 37402

**Subject: 168101 / 305069 – Manhole Rehabilitation – Waste Resources Division –  
Public Works Department**

Dear Mr. Holland:

Council approval is recommended to issue a twelve (12) month blanket contract for Manhole Rehabilitation, Waste Resource Division, Public Works Department, with the option for two (2) additional twelve (12) month terms for an estimated annual amount of \$250,000.

The invitation to bid was sent to nine (9) vendors as well as formally advertised. Since only one (1) bid was received, it was not opened. The invitation to bid was re-advertised but no additional bids were received. Bid is retained on file in the Purchasing Office for your review upon request.

#### Vendors

Video Industrial Services, Inc

I recommend awarding the blanket contract for Manhole Rehabilitation to Video Industrial Services, Inc, 7721 2nd Avenue North, Birmingham, AL 35206, as the best complete bid meeting all specifications for the City of Chattanooga.

Respectfully yours,

Bonnie Woodward  
Director of Purchasing

BW/mlm

Attachments

Requisition: 168101

Bid #: 305069

Description: Manhole Rehabilitation

Video Industrial Services, Inc

Item #	Item Description	Unit Price	Qty.	Extended Price
--------	------------------	------------	------	----------------

1	Per Vertical Foot for Labor Plus Equipment	Foot	\$ 385.00	500	\$ 192,500.00
---	--	------	-----------	-----	---------------

2	Percent Markup on Subcontractors	Each	0%		
---	----------------------------------	------	----	--	--

Totals: \$ 192,500.00

**Talley Construction Company**  
1751 McFarland Avenue  
Rossville, GA 30741

**Mayse Construction Company**  
4659 B Shallowford Road  
Chattanooga, TN 37411

**Thomas Brothers Construction  
Company**  
7849 Dayton Pike  
Hixson, TN 37343

**Dillard Construction Company**  
2631 Rhea County Highway  
Dayton, TN 37321

**Ground Works Solutions**  
4759 Drane Field Road  
Lakeland, FL 33811

**Vulcan Painters, Inc**  
P.O. Box 1010  
Bessemer, AL 351021

**Hill Services**  
4940 Covington Way  
Memphis, TN 38128

**Milliken Infrastructure**  
920 Milliken Road  
Spartanburg, SC 29304

**Alternative Lining Technologies**  
10075 Sedroc Industrial Drive SW  
Byron Center, MI 49315

# BID SOLICITATION



**City of Chattanooga**  
 101 East 11th Street, Suite G13  
 Chattanooga, TN 37402

**BID OPENING DATE AND TIME:**  
 25-APR-18 at 2:00 PM

**BID NUMBER: 305069**

**BUYER:**  
**PHONE #:** (423) 643-7230  
**DELIVERY REQUIRED:**

SEALED BIDS

Mail or submit two (2) signed copies of bid form to this office in the enclosed envelope. Retain one copy for your file.

V  
E  
N  
D  
O  
R

RFQ

M  
A  
I  
L  
T  
O

City of Chattanooga  
 101 East 11th Street, Suite G13  
 Chattanooga, TN 37402

Item	Class-Item	Quantity	Unit	Unit Price	Total
------	------------	----------	------	------------	-------

Requisition No.: 168101  
 Ordering Dept.: Waste Resources  
 Buyer: Geoffrey Hipp 423-643-7233  
 .....

**DESCRIPTION:**  
 This shall be a twelve (12) month blanket contract for Manhole Rehabilitation Services for the Waste Resources Division. The contract may be renewed for two (2) additional twelve (12) month terms under the same Terms and Conditions by Mutual Agreement. The City of Chattanooga and the Contractor may bilaterally extend the contract by Written Confirmation by both parties at least 30 days prior to the contract's current expiration date into any successive term as provided herein.  
 .....

**ATTACHMENTS:**  
 - Specifications  
 - Iran Divestment Act  
 - Affirmative Action Plan  
 - Standard Terms and Conditions:  
 (<http://www.chattanooga.gov/purchasing/standard-terms-and-conditions>)  
 .....

\*\*\* BIDS MUST BE RECEIVED NO LATER THAN \*\*\*  
 \*\*\*\*\* 2:00 PM ON APRIL 25, 2018 \*\*\*\*\*  
 .....

PLEASE SUBMIT BIDS IN DUPLICATE INDICATING  
 BID NUMBER (305069) ON OUTSIDE PACKAGING  
 \*

ALL ITEMS MUST BE QUOTED F.O.B. DESTINATION, FREIGHT ALLOWED.  
 .....

**NOTE:** All bids received are subject to the terms and conditions contained herein and as listed in the above referenced website. The undersigned Bidder acknowledges having received, reviewed, and agrees to be bound to these terms and conditions, unless specific written exceptions are otherwise stated.

The City of Chattanooga reserves the right to reject any and/or all bids, waive any informalities in the bids received, and to accept any bid which in its opinion may be for the best interest of the city.

The City of Chattanooga will be non-discriminatory in the purchase of all goods and services on the basis of race, color, or national origin.  
 .....

**PRICE ESCALATION CLAUSE:**  
 All prices under this contract shall remain fixed during each twelve (12) month contract period. If as a result of a general change in prices or discounts, the contractor has changed prices to all of its customers, then, at the time of contract renewal, the price under this contract may be adjusted accordingly after acceptance. All price increases must be justified by providing a copy of the prevailing labor wage or material cost increases. Prompt notice of price changes (increases or reductions) must be furnished to the Purchasing Agent at least 30 days prior to the requested effective date and the prices for these services/materials shall remain firm for twelve (12) months. The effective date of price increases shall be the date the Purchasing Agent accepts the price changes or the effective date of increase stated by contractor's notice to Purchasing Agent, whichever is later.  
 .....

PLEASE PROVIDE US WITH THE FOLLOWING INFORMATION:

Company Name Video Industrial Services, Inc.  
 Address 7721 2nd Ave N Birmingham, AL 35206  
 Phone/Toll-Free No. 205-798-0300  
 Fax No. 205-798-6211  
 E-Mail Address dmahan@videoindustrial.com

# BID SOLICITATION



**City of Chattanooga**  
 101 East 11th Street, Suite G13  
 Chattanooga, TN 37402

**BID OPENING DATE AND TIME:**  
 25-APR-18 at 2:00 PM  
**BID NUMBER:** 305069

**BUYER:**  
**PHONE #:** (423) 643-7230  
**DELIVERY REQUIRED:**

**SEALED BIDS**

Mail or submit two (2) signed copies of bid form to this office in the enclosed envelope. Retain one copy for your file.

**V  
E  
N  
D  
O  
R**

RFQ

**M  
A  
I  
L  
I  
N  
G**

City of Chattanooga  
 101 East 11th Street, Suite G13  
 Chattanooga, TN 37402

Item	Class-Item	Quantity	Unit	Unit Price	Total
Contact Person's Name <u>Drew Mahan</u> Estimated Delivery _____ Minority-Owned Business ___ Small Business ___ Veteran ___ Minority Woman Owned Business ___ Disabled Veteran ___ Women-Owned Business <u>X</u>					

**NOTE: ALL BIDS RECEIVED ARE SUBJECT TO THE TERMS AND CONDITIONS**

The City is Exempt from all Federal and State Tax.  
 Bids will be received at the above mentioned address.

TERMS OF PAYMENT: Net 60

TELEPHONE NUMBER: 205-798-0300

ALL BIDS MUST BE SIGNED – The undersigned offers the above quoted prices under the conditions contained herein.

COMPANY: Video Industrial Services, Inc.

SIGNATURE:

NAME AND TITLE: Drew Mahan - Executive Vice President



# BID SOLICITATION



City of Chattanooga  
101 East 11th Street, Suite G13  
Chattanooga, TN 37402

**SEALED BIDS**

Mail or submit two (2) signed copies of bid form to this office in the enclosed envelope. Retain one copy for your file.

**BID OPENING DATE AND TIME:**  
25-APR-18 at 2:00 PM

**BID NUMBER:** 305069

**BUYER:**  
**PHONE #:** (423) 643-7230  
**DELIVERY REQUIRED:**

**V  
E  
N  
D  
O  
R** RFQ

**M  
A  
I  
L  
T  
O** City of Chattanooga  
101 East 11th Street, Suite G13  
Chattanooga, TN 37402

Item	Class-Item	Quantity	Unit	Unit Price	Total
1	Per Vertical Foot for labor plus equipment	500	Foot	<u>\$ 385.00</u>	<u>\$ 192,500.00</u>
2	Percent Markup on Subcontractors	10	Each	—	—

**NOTE: ALL BIDS RECEIVED ARE SUBJECT TO THE TERMS AND CONDITIONS**

ALL BIDS MUST BE SIGNED – The undersigned offers the above quoted prices under the conditions contained herein.

The City is Exempt from all Federal and State Tax.  
Bids will be received at the above mentioned address.

COMPANY: Video Industrial Services, Inc.

TERMS OF PAYMENT: Net 60

SIGNATURE:

TELEPHONE NUMBER: 205-798-0300

NAME AND TITLE: Drew Mahan - Executive Vice President

**No Contact/No Advocacy**

**Notice Receipt**

City of Chattanooga  
Purchasing Division

**For Submission with Sealed Bid Solicitation Responses:**

\_\_\_\_\_ Drew Mahan \_\_\_\_\_ (Vendor Agent name), states that:

(1) He/She is the owner, partner, officer, representative, or agent of \_\_\_\_\_ Video Industrial Services, Inc.

\_\_\_\_\_ (Business name), the Submitter of the  
attached sealed solicitation response to Solicitation # 305069 \_\_\_\_\_, and said

Business has taken notice, and will abide by the following No Contact and No Advocacy clauses:

**NO CONTACT POLICY:** After the posting of this solicitation, a potential submitter is prohibited from directly or indirectly contacting any City of Chattanooga representative concerning the subject matter of this solicitation, unless such contact is made with the Purchasing Division.

**NO ADVOCATING POLICY:** To ensure the integrity of the review and evaluation process, companies and/or individuals submitting sealed solicitation responses, as well as those persons and/or companies formally/informally representing such submitters, may not directly or indirectly lobby or advocate to any City of Chattanooga representative.

**Any business entity and/or individual that does not comply with the No Contact and No Advocating policies may be subject to the rejection or disqualification of its solicitation response from consideration.**

Submitter Signature:

Printed Name:

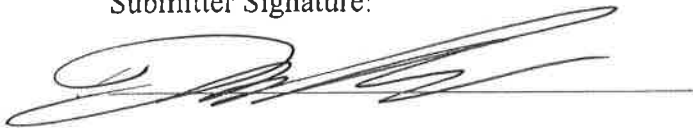

\_\_\_\_\_ Drew Mahan \_\_\_\_\_

Title: Executive Vice President \_\_\_\_\_

Date: 4/20/18 \_\_\_\_\_

Chapter No. 817 (HB0261/SB0377). "Iran Divestment Act" enacted.  
Vendor Disclosure and Acknowledgement

By submission of this bid, each bidder and each person signing on behalf of any bidder certifies, and in the case of a joint bid each party thereto certifies as to its own organization, under penalty of perjury, that to the best of its knowledge and belief that each bidder is not on the list created pursuant to § 12-12-106.

(SIGNED)



(PRINTED NAME)

Drew Mahan

(BUSINESS NAME)

Video Industrial Services, Inc.

(DATE)

4/23/18

For further information, please see website:

[https://www.tn.gov/assets/entitles/generalservices/cpo/attachments/List\\_of\\_persons\\_pursuant\\_to\\_Tenn.\\_Code\\_Ann.\\_12-12-106,\\_Iran\\_Divestment\\_Act-July.pdf](https://www.tn.gov/assets/entitles/generalservices/cpo/attachments/List_of_persons_pursuant_to_Tenn._Code_Ann._12-12-106,_Iran_Divestment_Act-July.pdf)

## Affirmative Action Plan

The City of Chattanooga is an equal opportunity employer and during the performance of this Contract, the Contractor agrees to abide by the equal opportunity goals of the City of Chattanooga as follows:

1. The Contractor will not discriminate against any employee or applicant for employment because of race, color, religion, sex, national origin, or handicap. The Contractor will take affirmative action to ensure that applicants are employed, and that employees are treated during employment without regard to their race, color, religion, sex, national origin, or handicap. Such action shall include, but not be limited to, the following: employment, upgrading, demotion or transfer, recruitment or recruitment advertising, layoff or termination, rates of pay or other forms of compensation, and selection for training including apprenticeship. The Contractor agrees to post in conspicuous places, available to employees and applicants for employment, notices setting forth the provisions of this nondiscrimination clause.
2. The Contractor will, in all solicitations or advertisements for employees placed by or on behalf of the Contractor, state that all qualified applicants will receive consideration for employment without regard to race, color, religion, sex, national origin, or handicap.
3. The Contractor will send to each labor union or representative of workers with which he/she has a collective bargaining agreement or other contract or understanding, a notice advising said labor union or workers' representatives of the Contractor's commitments under this section, and shall post copies of the notice in conspicuous places available to employees and applicants for employment.
4. During the term of all construction contracts or subcontracts in excess of \$10,000 to be performed for the City of Chattanooga, the following non-discriminatory hiring practices shall be employed to provide employment opportunities for minorities and women:
  - a. All help wanted ads placed in newspapers or other publications shall contain the phrase "Equal Employment Opportunity Employer".
  - b. Seek and maintain contracts with minority groups and human relations organizations as available.
  - c. Encourage present employees to refer qualified minority group and female applicants for employment opportunities.
  - d. Use only recruitment sources which state in writing that they practice equal opportunity. Advise all recruitment sources that qualified minority group members and women will be sought for consideration for all positions when vacancies occur.

5. Minority statistics are subject to audit by City of Chattanooga staff or other governmental agency.
6. The Contractor agrees to notify the City of Chattanooga of any claim or investigation by State or Federal agencies as to discrimination.



\_\_\_\_\_  
(Signature of Contractor)

Executive Vice President      Video Industrial Services, Inc.

\_\_\_\_\_  
(Title and Name of Company)

4/23/18

\_\_\_\_\_  
(Date)

**ADDENDUM NO: 1**

**REQ NO: 168101**

**FINAL SUBMITTAL: May 2, 2018 2:00 PM EST**

**FINAL QUESTIONS: N/A**

**Department: Waste Resource Division, Public Works**

**Changes to Bid No. 305069:**

**Bid Opening has changed to May 2, 2018 at 2:00 PM EST due to only receiving one (1) bid. Per Purchasing Rules the bid opening has to be extended one (1) week to allow for vendors to submit bids.**

**Original bid opening was April 25, 2018 at 2:00 PM EST**

**Req No: 168101 Manhole Rehabilitation Services**

**PLEASE SIGN ONE (1) COPY OF ADDENDUM AND RETURN TO THE PURCHASING DEPARTMENT. RETAIN THE OTHER COPY FOR YOUR FILES.**

**Name:** DREW MAHAN

**Company:** VIDEO INDUSTRIAL SERVICES, INC.

*mmckeel@chattanooga.gov*

**CITY OF CHATTANOOGA  
PURCHASING DEPARTMENT  
Mark McKeel  
101 East 11<sup>th</sup> Street  
City Hall Suite G13  
CHATTANOOGA, TN 37402  
TELE: (423) 643-7236  
FAX: (423) 643-7244**



# City of Chattanooga

Mayor Andy Berke

May 30, 2018

Mr. Justin Holland  
Administrator, Public Works Department  
Waste Resource Division  
1250 Market Street, Suite 2100  
Chattanooga, TN 37402

**Subject: R170981 – Purchase of 1.5 MW Portable Generator – Waste Resource  
Division – Public Works Department**

Dear Mr. Holland:

Council approval is recommended to issue a purchase order for one (1) 1.5 MW Portable Generator, with a 5-Year Warranty, for Waste Resource Division, Public Works Department.

This purchase from Stowers Machinery Corporation will be in the amount of \$462,290.00 utilizing the NJPA Contract No. 120617. A detailed quote is attached.

TCA 6-56-304.2 allows this single source blanket contract exempted from the usual advertising and bidding requirements.

I recommend approval of this purchase to Stowers Machinery Corporation, 4066 S. Access Road, Chattanooga, TN 37406, in the amount of \$462,290.00.

Respectfully yours,

Bonnie Woodward  
Director of Purchasing

BW/mlm

Attachments



5/9/18

# NJPA CONTRACT #120617

Re: City of Chattanooga: Moccasin Bend WWTP- EQ BASIN

Thank you for allowing Stowers Industrial Power to offer the following equipment and services.

General description

**One USED CAT 2007 Model XQ1500.**

**SN- BNR00347.**

**Current hours are 606.**

**CABLE**

**60- 50' sections of 4/0 type w/ cable with cam lock ends**

**30- male pigtails**

**30- female pigtails**

**4 hour Load Bank Test-documentation to be provided.**

**WARRANTY**

**Advantage Platinum – 60 months 2500hrs- (\$16,290.00 included in the total price below)**

**Delivery to Moccasin Bend WWTP**

**Price for One USED CAT XQ1500 Portable Diesel fueled generator with equipment listed, price f.o.b. Job Site, less taxes (if applicable).....\$ 462,290.00**

**Published lead time at the time of the above date is 1-2 weeks ARO.**

**Quotation Notes:**

1. **WE HAVE DETAILED THE EQUIPMENT PROPOSED. PLEASE REVIEW YOUR SPECIFICATIONS TO BE SURE THAT THE EQUIPMENT DESCRIBED ABOVE MEETS YOUR REQUIREMENTS.**
2. This quotation covers items listed herein and does not constitute a specific job proposal.
3. All equipment furnished loose for installation by others unless specifically listed as installed.
4. We are quoting this equipment as a material supplier only; we do not include any offloading, installation, concrete pad, conduit, wiring, lugs, fuel, fuel piping, and other misc. hardware.
5. Start-Up, Testing, & Training to be performed during normal business hours unless specifically indicated otherwise.
6. Relay and/or System Coordination Study are not included unless specifically noted.
7. Telephone and verbal orders are to be confirmed in writing.
8. We reserve the right to correct errors or omissions.
9. Stowers Machinery is not responsible for occurrences beyond our control.
10. Sale is contingent upon customer signing a Stowers Machinery Purchaser Agreement Form.
11. This quotation is made subject to Stowers Machinery Standard Terms and Conditions.
12. Contracts which include penalties or liquidated damage clauses for failure to meet promised shipping dates are not accepted by or binding on Stowers Machinery, unless accepted, and confirmed in writing
13. Delivery dates listed above are only estimates based on current delivery times from the manufacturers; they are subject to change at any time. Firm delivery dates can only be obtained after the manufacturer has released equipment for production. Release for production occurs after the customer has approved submittals in writing or the customer's representative.
14. Standard payment terms are net due upon invoice or customer account status is final determination
15. This quotation is good for 30 days from date listed at the top of quotation

*Please call Andy Downs for additional information or to place an order. We look forward to working with you.*

Signed \_\_\_\_\_ Date \_\_\_\_\_ Firm \_\_\_\_\_



Sincerely,  
Andy Downs  
Commercial Engine Sales  
423-698-6943 main  
423-463-2131 mobile  
[adowns@slowerscal.com](mailto:adowns@slowerscal.com)



4/16/18

Re: City of Chattanooga: Moccasin Bend WWTP- EQ BASIN

Thank you for allowing Stowers Industrial Power to offer the following equipment and services.

General description

One USED CAT 2007 Model XQ1500.

SN- BNR00347.

Current hours are 606.

CABLE

60- 50' sections of 4/0 type w/ cable with cam lock ends  
30- male/female pigtails

4 hour Load Bank Test- documentation to be provided.  
Delivery to Moccasin Bend WWTP

Price for One USED CAT XQ1500 Portable Diesel fueled generator with equipment listed, price f.o.b. Job Site,  
less taxes (if applicable).....\$ 446,000.00

Published lead time at the time of the above date is 1-2 weeks ARO.

Quotation Notes:

1. WE HAVE DETAILED THE EQUIPMENT PROPOSED. PLEASE REVIEW YOUR SPECIFICATIONS TO BE SURE THAT THE EQUIPMENT DESCRIBED ABOVE MEETS YOUR REQUIREMENTS.
2. This quotation covers items listed herein and does not constitute a specific job proposal.
3. All equipment furnished loose for installation by others unless specifically listed as installed.
4. We are quoting this equipment as a material supplier only; we do not include any offloading, installation, concrete pad, conduit, wiring, lugs, fuel, fuel piping, and other misc. hardware.
5. Start-Up, Testing, & Training to be performed during normal business hours unless specifically indicated otherwise.
6. Relay and/or System Coordination Study are not included unless specifically noted.
7. Telephone and verbal orders are to be confirmed in writing.
8. We reserve the right to correct errors or omissions.
9. Stowers Machinery is not responsible for occurrences beyond our control.
10. Sale is contingent upon customer signing a Stowers Machinery Purchaser Agreement Form.
11. This quotation is made subject to Stowers Machinery Standard Terms and Conditions.
12. Contracts which include penalties or liquidated damage clauses for failure to meet promised shipping dates are not accepted by or binding on Stowers Machinery, unless accepted, and confirmed in writing
13. Delivery dates listed above are only estimates based on current delivery times from the manufacturers; they are subject to change at any time. Firm delivery dates can only be obtained after the manufacturer has released equipment for production. Release for production occurs after the customer has approved submittals in writing or the customer's representative.
14. Standard payment terms are net due upon invoice or customer account status is final determination
15. This quotation is good for 30 days from date listed at the top of quotation

**NEW WARRANTY:**

The Equipment and/or machinery described herein are sold subject only to those warranties provided by the manufacturer. Caterpillar standard two-year limited warranty on Caterpillar parts. The Seller does not join in any such manufacturer's warranties. The Seller gives no warranty, express or implied, as to description, quality, merchant ability, fitness for any particular purpose, productiveness, or any other matter, of any equipment which Seller shall supply. The seller shall be no way responsible for their proper use and service, and the Purchaser hereby waives all rights of refusal and return of equipment.

Please call Andy Downs for additional information or to place an order. We look forward to working with you.

Signed \_\_\_\_\_ Date \_\_\_\_\_ Firm \_\_\_\_\_

Sincerely,  
Andy Downs  
Commercial Engine Sales  
423-698-6943 main  
423-463-2131 mobile  
[adowns@stowerscat.com](mailto:adowns@stowerscat.com)



## Caterpillar Inc. Alternative Energy/Generators



**Contract#:** 120617-CAT  
**Category:** Energy Solutions  
**Maturity Date:** 01/29/2022

Overview

Contract Documentation

Pricing

Marketing Materials

NJPA Contact Information

### HOW TO PURCHASE

Our step-by-step guide



### Vendor Contact Info

David Stutzman  
Direct Phone: 713-899-3488  
[Stutzman.David@cat.com](mailto:Stutzman.David@cat.com)  
[www.cat.com](http://www.cat.com)

Big or Small. Simple or Complex. Any size or any shape. In any regulatory environment. When you need power, Caterpillar is equal to the challenge of meeting the world's emergency and standby needs with an unparalleled line of diesel and natural gas generator sets. The experienced Caterpillar Dealer Network can deliver power systems and the support you need. Caterpillar is proud to be a National Joint Powers Alliance vendor and is excited about the the opportunity to provide NJPA Members with power solutions.

This contract is offering a Free 4 year Extended Service Coverage on qualifying Diesel and Natural Gas Generators. See your local Cat Dealer for additional details.

[Find a Dealer](#)





Atlanta

Huntsville  
Decatur

Chattanooga  
2

Nantahala  
National Forest

Chattahoochee  
National Forest

Greenville Spartan

Map data © 2018 Google

Dark Gray pins Represent Home Dealer for Your Area

## SEARCH RESULTS

UNITS:  US  METRIC

1 - 5 of 50 Listings

1  2  3  4  5  6  7  8  9  10

1

### STOWERS CAT

4066 S ACCESS RD  
Chattanooga Tennessee, 37406

3.0 Miles

[Driving Directions](#)  
[View on Map](#)

### Machines

1 865 546-1414 - AFTERHOURS  
1 423 698-6947 - FAX  
1 423 698-6943 - GENERAL INFO

### E-Mails:

[GENERALINFO@STOWERSCAT.COM](mailto:GENERALINFO@STOWERSCAT.COM)

### Web:

[www.stowerscat.com](http://www.stowerscat.com)

### Machines:

MONDAY 730 - 1730  
TUESDAY 730 - 1730  
WEDNESDAY 730 - 1730  
THURSDAY 730 - 1730  
FRIDAY 730 - 1730

### SERVICES OFFERED

**FORM E**  
**CONTRACT ACCEPTANCE AND AWARD**



(Top portion of this form will be completed by NJPA if the vendor is awarded a contract. The vendor should complete the vendor authorized signatures as part of the RFP response.)

NJPA Contract #: 120617-CAT

Proposer's full legal name: Caterpillar Inc.

**Based on NJPA's evaluation of your proposal, you have been awarded a contract. As an awarded vendor, you agree to provide the products and services contained in your proposal and to meet all of the terms and conditions set forth in this RFP, in any amendments to this RFP, and in any exceptions that are accepted by NJPA.**

The effective date of the Contract will be January 29, 2018 and will expire on January 29, 2022 (no later than the later of four years from the expiration date of the currently awarded contract or four years from the date that the NJPA Chief Procurement Officer awards the Contract). This Contract may be extended for a fifth year at NJPA's discretion.

**NJPA Authorized Signatures:**

  
\_\_\_\_\_  
NJPA DIRECTOR OF COOPERATIVE CONTRACTS  
AND PROCUREMENT/CPO SIGNATURE

Jeremy Schwartz  
(NAME PRINTED OR TYPED)

  
\_\_\_\_\_  
NJPA EXECUTIVE DIRECTOR/CEO SIGNATURE

Chad Coquette  
(NAME PRINTED OR TYPED)

Awarded on January 25, 2018

NJPA Contract # 120617-CAT

**Vendor Authorized Signatures:**

The Vendor hereby accepts this Contract award, including all accepted exceptions and amendments.

Vendor Name Caterpillar Inc.

Authorized Signatory's Title General Manager - IPSD Power Generation

  
\_\_\_\_\_  
VENDOR AUTHORIZED SIGNATURE

Bart Myers  
\_\_\_\_\_  
(NAME PRINTED OR TYPED)

Executed on January 26, 2018

NJPA Contract # 120617-CAT

# RENTAL

# CATERPILLAR



## XQ1500 SOUND ATTENUATED POWER MODULE

60 Hz

### FEATURES



#### EMISSIONS

EPA and CARB Emissions Certified for non-road mobile applications.



#### CAT® DIESEL GENERATOR SETS

Factory designed, certified prototype tested with torsional analysis. Production tested and delivered to you in a package that is ready to be connected to your fuel and power lines. Electric Power Design Pro computer sizing available. Supported 100% by your Caterpillar dealer with warranty on parts and labor. Extended warranty available in some areas. The generator set was designed and manufactured in an ISO 9001 compliant facility. Generator set and components meet or exceed the following specifications: AS1359, AS2789, ABGSM TM3, BS4999, DIN6271, DIN6280, EGSA101P, JEM1359, IEC 34/1, ISO3046/1, ISO8528, NEMA MG1-22.



#### CATERPILLAR® SR4B GENERATOR

Single bearing, wye connected, static regulated, brushless permanent magnet excited generator designed to match the performance and output characteristics of the Caterpillar diesel engine that drives it.



#### RELIABLE, FUEL EFFICIENT DIESEL

The compact, four-stroke-cycle diesel engine combines durability with minimum weight while providing dependability and economy. The fuel system operates on a variety of fuels.

#### CATERPILLAR® COOLING SYSTEM

Sized compatible to rating with energy efficient fan and core.

#### CATERPILLAR® SWITCHGEAR

Single unit or optional paralleling components. Circuit breakers, bus bars, and connection panel ready to connect.

#### EXCLUSIVE CATERPILLAR® VOLTAGE REGULATOR

Three-phase sensing and adjustable Volts-per-Hertz regulation give precise control, excellent block loading, and constant voltage in the normal operating range.

#### SOUND ATTENUATED ISO CONTAINER

For ease of transportation and protection. Meets 70 dBA at 50 ft or below per SAE J1074 measurement procedure.



WHERE THE WORLD TURNS FOR POWER

## FACTORY INSTALLED STANDARD & OPTIONAL EQUIPMENT

System	Standard	Optional
<b>Engine</b>	Air cleaner, with service indicator Batteries Filters; fuel, RH with service indicators; lubricating oil Insulated muffler Jacket water heater Pump, fuel priming — RH Radiator Service meter Standard eight-gauge instrument panel Sump pump Governor Electronic ADEM II	
<b>Generator</b>	SR4B brushless, 480 volt, PM excited three-phase with digital voltage regulator, space heater	
<b>Containerized Module</b>	Air intake louvers Bus bar access door Fuel tank — 4730 L (1250 Gal) UL listed Fuel/water separator 110 VAC/24 VDC lighting Sound attenuated (75 dBA @ 50 ft) ISO hi cube container Lockable doors Stainless steel hardware and hinges Vertical radiator and exhaust discharge plenum	
<b>Cooling</b>	Standard cooling provides 110° ambient at prime rating	
<b>Switchgear</b>	Floorstanding switchgear with EMCP II components Automatic start/stop with cooldown timer Battery charger, heavy duty 20A Protection: 32, 59 Circuit breaker, electrically operated Connection terminals, 3-phase and neutral Automatic paralleling Auxiliary power connections for jacket water heater, battery charger, space heaters	Meters: power factor, KW, PF, W/WHM, synchroscope, KVAR Protection: 27, 40, 810, 81U CIM, CCM, remote annunciation Plug and peak shave utility conversion panel

## SPECIFICATIONS

### CAT SR4B GENERATOR

Type . . . . . Static regulated brushless PM excited  
 Construction . . . . . Single bearing, close coupled  
 Three-phase . . . . . Wye connected — 6 lead  
 Insulation . . . . . Class H — 2 extra dips and bakes on random wound units  
 Enclosure . . . . . Drip proof  
 Alignment . . . . . Pilot shaft  
 Overspeed capability . . . . . 130%  
 Voltage regulator . . . . . 3-phase sensing with Volts-per-Hertz  
 Voltage regulation . . . . . Less than ± 0.5%  
 Voltage gain . . . . . Adjustable to compensate for engine speed droop and line loss  
 Wave form . . . . . Less than 5% deviation  
 TIF . . . . . Less than 50  
 THD . . . . . Less than 3%

### CAT® 3512B ENGINE

V-12, 4-stroke-cycle diesel  
 Bore — mm (in) . . . . . 170 (6.7)  
 Stroke — mm (in) . . . . . 190 (7.5)  
 Displacement — L (cu in) . . . . . 51.8 (3158)  
 Aspiration . . . . . Turbocharged-Aftercooled



## TECHNICAL DATA

<b>Power Rating</b> 60 Hz	ekW	<b>Standby</b> 1500	<b>Prime</b> 1360
<b>Engine and Container Information</b> Engine Model Container size Container dimensions	m (ft)	3512B 12 (40) see below	
<b>Fuel Capacity Hours of Operation at 60% Load Factor</b> 4732 L (1250 Gal) Standard 12 m (40 ft) 9464 L (2500 Gal) Optional 12 m (40 ft)	hours hours	11 22	12 24
<b>Approximate Weight (Dry) — Container with Generator Set and Switchgear</b> Including Container With Undercarriage	kg (lb) kg (lb)	22 680 (50,000) 26 765 (59,000)	

### Container Dimensions

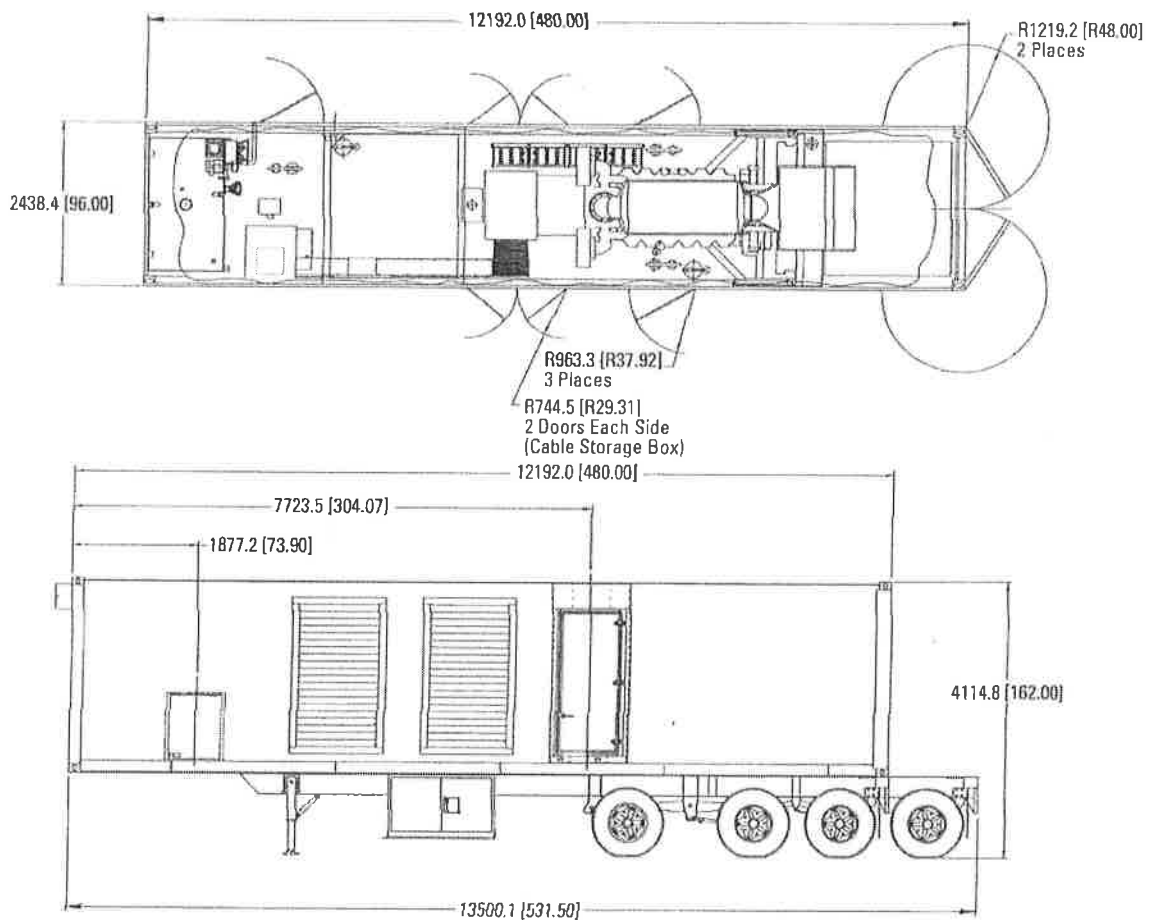

The power module must have support under the center when set on the ground.

Dimensions		
<b>Length</b>	12192.0 mm	480.00 in
<b>Width</b>	2438.4 mm	96.00 in
<b>Height</b>	4114.8 mm	162.00 in

## STANDARD CONTROLS

### 12 m (40 ft) CONTAINERS 480V/60 Hz

Floorstanding switchgear includes the following functions and features:

### ELECTRONIC MODULAR CONTROL PANEL (EMCP II) COMPONENTS

#### GENERATOR SET CONTROL (GSC)

##### Monitoring

Sequentially rotating, backlit LCD display of engine hours, engine rpm, DC battery voltage, oil pressure, and water temperature. Includes pushbutton to hold display on any single parameter.

##### Protection

##### Shutdowns:

Overspeed, overcrank, high water temperature, low oil pressure, and emergency stop. With LED indicator for each condition.

##### Alarms:

Low coolant level

##### AC Metering

Three-phase volts (L-L), amperes and frequency with phase select pushbutton, on backlit LCD. Metering accuracy is 0.5%.

##### Control

Automatic starting with field adjustable cycle crank, failure to start (overcrank), and cooldown timer.

##### Programming and Diagnostics

Includes field programmable set-points for engine control and monitoring variables and self diagnosis of EMCP II system component and wiring failures.

### ALARM MODULE

Flashing LED warnings for: low coolant temperature, high coolant temperature (pre-alarm), low oil pressure (pre-alarm), engine control switch not in automatic, and low DC voltage. Includes alarm horn and acknowledge pushbutton.

### ENGINE CONTROL SWITCH

Snap action rotary switch, four-position — off/reset, automatic, manual, stop/cooldown. Off/reset for engine shutdown and resetting faults, automatic for remote starting by customer contact closure, manual for local starting and manual paralleling, stop/cooldown for manual operation cooldown.

### ALARM ACKNOWLEDGE/LAMP TEST SWITCH

Three-position, spring return to center switch for alarm acknowledge and lamp test of all discrete indicating lamps. Lamp test shall also sound the alarm horn.

### ANNUNCIATION CIRCUITS

Upon receipt of an alarm or shutdown condition, the horn shall sound and an LED shall flash. Upon acknowledgement from alarm acknowledge/lamp test switch, the horn shall be silenced and the lamp steadied. LED shall be extinguished when ECS is placed in the off/reset position if the alarm condition has been corrected. Circuits are recurring such that the LED shall flash and the horn sound, should another fault occur even prior to correction of the initial fault.

### EMERGENCY STOP PUSHBUTTON

Mushroom head, twist to reset, causes engine shutdown and tripping of the generator circuit breaker. Prevents engine starting when depressed.

### MANUAL PARALLELING

Controls consisting of reverse power relay, synchronizing lights, and switch. Reverse power condition causes tripping of the generator circuit breaker, immediate engine shutdown, flashing of indicating lamp, and sounding of alarm horn.

### CIRCUIT BREAKER

Fixed mounted, three-pole, manually operated, molded case circuit breaker with solid state trip unit for overload (time overcurrent) and fault (instantaneous) protection. Includes DC shunt trip coil activated on any generator set monitored fault. Circuit breaker is sized for full load capacity of the generator set at 0.8 power factor.

### LOAD SHARE GOVERNOR

Electronic load sharing governor with speed adjust potentiometer, idle/rated switch, and isochronous/droop switch.

### VOLTAGE REGULATOR

Standard Caterpillar generator-mounted digital voltage regulator with voltage adjust rheostat mounted in the floorstanding switchgear.

## STANDARD CONTROLS (Continued)

### CURRENT TRANSFORMERS (3)

Five-ampere secondary with shorting terminal strips

### POTENTIAL TRANSFORMERS (3)

120 VAC secondary with primary and secondary fuse protection, two connected to the generator side of the circuit breaker, one connected to the load side of the circuit breaker.

### BUS BARS

Three-phase plus fully rated neutral bus bars with NEMA standard hole pattern for connection of customer load cables and generator cables. Bus bars are sized for full load capacity of the generator set at 0.8 power factor. Also includes ground bus, connected to the generator frame ground and container frame with holes for connection of field ground cable. Bus bars are accessible from outside of the power module via hinged, lockable cable access door.

### ACCESSORY POWER

#### 3500 Power Modules

Three 230 VAC (50 Hz units) or 120 VAC (60 Hz units) shore power connections for jacket water heaters, generator space heater, and battery charger.

### BATTERY CHARGER

24 VDC/20A battery charger with float/ equalize modes and charging ammeter.

## 4160V POWER MODULES

Similar to 480V units except for the following:

All bus bars are silver plated copper  
Generator circuit breaker, 3-pole, vacuum type, manually operated with 24 VDC shunt trip. Sized for generator voltage and current ratings. Includes draw-out overcurrent relay, with instantaneous setting, ANSI device 50/51.





# Extended Coverage Quote Confirmation

Quote Number :

## Customer Quote

Extended Coverage Quote Provider : Caterpillar

Quote Status : Draft-NOT ACCEPTED

Quote Date : 05/16/2018

Price Expiration Date :

**Customer Information :**

HO PENN MACHINERY  
225 RICHARD ST  
NEWINGTON  
CONNECTICUT  
06111-5046  
UNITED STATES

**Dealer Information :**

STOWERS MCHY  
6301 OLD RUTLEDGE PIKE  
PO BOX 14802  
KNOXVILLE  
TENNESSEE  
37924-4831  
UNITED STATES  
jamberson@stowerscat.com

**Product Information :**

Model : PM3512  
Serial# : BNR00347  
Type : Published  
Emissions Control Indicator : NONE  
Original Delivery Date : 05/21/2008  
Product Status : No Delayed Coverage Start  
Current Usage : 606 Hours

Coverage	P/L	Duration	Usage	Deductible	Amount
ADV GENSET PLATINUM	PARTS AND LABOR	60 Months	2500 Hours	0.00	16,290.00

**Other:**

Administration Fee

Late Fee

Tax

Total Customer Amount

0.00

Currency

USD

**Additional Comments :**

**Notes:**

1. This quote is a non-binding price indication.
2. Dealers may refer to Equipment Protection Plan Administrative Manual or Engine Extended ESC coverage for covered component details.
3. Late Fees may apply to Engine Extended Coverage Cost(s) at the time of Enrollment.
4. All deductibles displayed in USD.
5. GST Not Included
6. Caterpillar branded machine product quotes do not include Year 1 – Labor Only coverage within the Year 2 & Beyond coverages (except for limited EPP programs, which include both Year 1 – Labor Only and Year 2 & Beyond coverage)



# Extended Coverage Quote Confirmation

## Customer Quote

Quote Number :

---

Customer Signature

Date

Dealer Signature

Date

Thank you for your business!

2120 West End Avenue, Nashville, TN 37203  
Toll Free: 1(800) 248-4228

## I. INTRODUCTION

This Extended Service Coverage ("ESC") Certificate, herein referred to as the Contract, is specifically for Cat Electric Power Products and is an important part of the Provider's continuing effort to provide "you" with superior value and product support.

## II. TERMS AND CONDITIONS

This Contract defines coverage, less any applicable deductible, for the "cost" of a "mechanical breakdown" under normal use during the "coverage period" due to a defect in material or factory workmanship of "covered components". This Contract is subject to the applicable exclusions listed under Section VIII. **EXCLUSIONS AND LIMITATIONS**. The Registration Certificate, page 1 of this Contract, must be completed in its entirety on the date of registration.

"You" should purchase this Contract on the "covered equipment's" original purchase date from an "authorized dealer". Certain fees, penalties and coverage availability limits may apply for Extended Service Coverage Contracts requested after the original purchase date.

"You" must contact an "authorized dealer" for complete details.

For New "ESC", the "coverage period" under this Contract starts at the "delivery date" of the "covered equipment". No claim will be paid until this Contract is registered.

For Advantage "ESC", the "coverage period" under this Contract starts:

1. The date of successful completion of the Advantage Certification Inspection for "covered equipment" not awaiting resale, or within 12 months from the original date of the Advantage Certification Inspection for "covered equipment" awaiting resale, or
2. If no inspection is required, see Section XVI. **EXTENDED SERVICE COVERAGE CONDITIONS**, coverage is effective on the date the Contract is signed as indicated on the bottom of the Registration Certificate, or
3. The transfer of coverage from an "authorized dealer" to "you".

Under this contract, coverage "upgrade or coverage continuation" for New "ESC" and Advantage "ESC" starts at the date of registration of the upgraded or continuation terms, conditions and coverage level.

## III. DEFINITIONS

"Authorized dealer" means a dealer authorized by the manufacturer to sell, service and repair the "covered equipment".

"Cost(s)" means the usual and customary charges as determined by the manufacturer for parts, labor, and other allowances necessary to repair or replace the parts "covered components" as specified in Section XIV. **COVERED COMPONENTS**. Replacement parts will be genuine manufacturers' parts when performing repairs and may include new, remanufactured or Caterpillar approved repaired components.

"Coverage period" means the period that commences with the start of coverage, as determined in Section II. **TERMS AND CONDITIONS**, and expires when time or hours of use, whichever occurs first, from the first date of coverage of the "covered equipment" exceeds the Extended Service Coverage Terms as specified on the Registration Certificate.

"Covered component" means the components listed and identified for the appropriate level of coverage in Section XIV. **COVERED COMPONENTS**.

Coverage may also be discontinued if an overhaul to the "covered equipment" becomes necessary as defined by key measures explained in the Operation and Maintenance Manual for this model and application. These key measures include, but are not limited to, valve recession, oil consumption, blow by, S.O.S. recommendations, total fuel consumed or service hours.

"Covered equipment" means the equipment identified by serial number for this Contract as recorded on the Registration Certificate and accepted by "us".

"Delivery date", also known as in-service date, is the beginning date of the Caterpillar standard warranty period to the initial user. Extended Service Coverage will be identified as "ESC" throughout this Contract.

"Repairer(s)" means a business entity "we" have authorized as a repair facility or "authorized dealer".

"Mechanical Breakdown" means the failure of any original or replacement "covered component" to work as it was designed to work in normal service, provided it has received customary maintenance as recommended in the manufacturer's Operation and Maintenance Manual.

"Upgrade or coverage continuation" is a change to one or more of the existing contract terms that result in a higher price for the coverage.

Contract terms subject to change include:

- 1) Coverage Level,
- 2) Coverage Months,
- 3) Coverage Hours, and/or
- 4) Deductible Level

### III. DEFINITIONS cont'd.

"Warranty" or "warranties" means the manufacturer's standard warranty or a "repairer's" guarantee or warranty.

"We," "us," and "our" mean the provider issuing this Contract and further defined in Section XVII. PROVIDER.

"You" and "your" mean the customer shown on the Registration Certificate.

"Aftertreatment" is a general term for a Tier 4 or Stage IIIB or IV emissions reduction device or system installed after the engine exhaust manifold and turbo to reduce regulated engine exhaust emissions. The systems may or may not be mounted on the engine.

"DPF" is an "aftertreatment" included in the Technical Marketing Information (TMI) as shipped consist or Order Inv. W/Eng Breakdown. The Cat diesel particulate filter "DPF" and related systems are designed to reduce Particulate Matter (PM) emissions levels in engines with Tier 4 or Stage IIIB or IV certification. "DPF" coverage must be ordered with engine coverage and can be ordered in combination with "SCR" coverage.

"SCR" is an "aftertreatment" included in the Technical Marketing Information (TMI) as shipped consist or Order Invoice with Engineering Breakdown. The Cat selective catalytic reduction system "SCR" and related urea based diesel exhaust fluid (DEF) systems used to reduce Oxides of Nitrogen (NOx) emission levels in engines with Tier 4 or Stage IIIB or IV certification. "SCR" coverage must be ordered with engine coverage and can be ordered in combination with "DPF" coverage.

### IV. "OUR" RESPONSIBILITIES

"We" will pay the "cost", less any applicable deductible, to repair, replace or rebuild the "covered equipment" for a "mechanical breakdown" of a "covered component". This work will be reimbursed at normal working hour labor rates at a "repairer's" place of business, or the "authorized dealer's" approved location of the "covered equipment".

"We" will provide, at "our" choice, new, remanufactured or repaired components when replacing or repairing any "covered components". Further, "we" will also pay for any component with a Cat part number that is rendered unserviceable by a "covered component" "mechanical breakdown" and reasonable labor to complete the repair.

"We" will restore the "covered equipment" to its operating condition prior to the "mechanical breakdown" by repairing and / or replacing only the required "covered components" and consequentially damaged Cat components necessary to correct the defect.

"We" will pay the reasonable labor to disconnect the "covered equipment" and reconnect the "covered equipment" to its attached equipment, mounting, and support systems, if required. Other parts or components removed in the process of the repair will be reinstalled as is, unless "you" authorize "your" additional expense to repair or replace.

"We" will also pay the reasonable "costs" of any consumables that are made unusable as a result of a "covered component" "mechanical breakdown".

### V. "YOUR" RESPONSIBILITIES

"You" shall operate, maintain and perform all recommended maintenance for the "covered equipment" according to the guidelines and recommendations as specified in the manufacturer's Operation and Maintenance Manual and as specified in Section XIV. COVERED COMPONENTS.

"You" shall utilize an "authorized dealer" for all scheduled oil sampling (S.O.S.) as specified in the manufacturer's Operation and Maintenance Manual by submitting samples promptly with necessary sample information at the specified service intervals and take the appropriate action as recommended by the S.O.S. results.

"You" shall be responsible for labor and material costs for "covered equipment" removal and reinstallation, except as stated in Section IV. "OUR" RESPONSIBILITIES.

"You" shall be responsible for all "costs" not covered by this Contract.

"You" shall document all scheduled maintenance and repairs of the "covered equipment". In the event of a "mechanical breakdown", present documentation of scheduled maintenance and repairs.

"You" shall ensure operators have training on proper operation of the "covered equipment" and follow guidelines of the Operations and Maintenance Manual.

### VI. COVERAGE TERRITORY

This Contract covers "covered equipment" worldwide except when coverage provided by this Contract would be in violation of any U.S. economic or trade sanctions, such as, but not limited to, sanctions administered and enforced by the U.S. Treasury Department's Office of Foreign Assets Control ("OFAC"), such coverage shall be null and void. Similarly, any coverage relating to or referred to in any certificates or other evidence of coverage or any claim that would be in violation of U.S. economic or trade sanctions, as described above, shall be null and void.

## VII. CLAIM PROCEDURES

In the event of a "mechanical breakdown" of the "covered equipment", "you" shall:

1. Take all reasonable steps to protect and safeguard the "covered equipment".
2. Report the "mechanical breakdown" promptly to "us" or a "repairer".
3. Promptly make the "covered equipment" available to a "repairer" for examination and repairs. Provide proof of this Extended Service Coverage Certificate by presenting "your" copy of the Registration Certificate.
4. Furnish "us" or a "repairer" with such information as may be reasonably required to assess the "mechanical breakdown".
5. Upon request, provide proof of compliance with the maintenance schedules as recommended in the manufacturer's Operation and Maintenance Manual, such as receipts or copies of work orders or invoices from "repairers" or "authorized dealers" showing the maintenance and services performed. Failure to show proof of proper maintenance may result in denial of coverage.

## VIII. EXCLUSIONS AND LIMITATIONS

This contract does not cover a "mechanical breakdown" caused by:

- > Wear and tear, normal wear out of components, corrosion, or physical or mechanical erosion;
- > Use of improper or contaminated fuel and/or fluid;
- > Failure to maintain proper level of lubricants and coolants;
- > "Repairer" workmanship;
- > "Covered equipment" modifications unless those modifications were performed at the authorized written request of "us";
- > Abuse, neglect, misuse or lack of customary maintenance, including, but not limited to:
  - I. Any failure to observe and comply with maintenance and servicing practices, specifications, intervals and requirements recommended or directed by the manufacturer;
  - II. Any failure to test oil samples according to an oil sampling program or analysis (including infrared analysis) as recommended or directed by the manufacturer; or
  - III. Any failure to inspect the "covered equipment" at such intervals as the manufacturer or "we" may recommend;
- > Failure of a component which is not a "covered component";
- > Application of the "covered equipment" for a use that is not approved by "us";
- > Use or establishment of fuel settings for "covered equipment" which are inconsistent with settings recommended by "us" or the manufacturer.

This Contract also does not pay for the "costs" arising from:

- > Acts of God, vermin, collision, fire, theft, vandalism, riot, explosion, lightning, earthquake, wind, storm, hail, water freezing, or flood
- > Performance-related complaints, including, but not limited to, adjustments to fuel settings or electronic unit injectors
- > The supply or consumption of lube oils, grease, coolant or air conditioner refrigerant, unless otherwise provided in this Contract or agreed by "us"
- > Work which improves operating performance, including, but not limited to, replacing or repairing "covered components" worn by normal use
- > Work associated with performing a Product Improvement Program (PIP) or Product Support Program (PSP) but which are not specifically paid for by the PIP or PSP
- > Any loss of or damage to a "covered component" occurring or arising outside the coverage territory
- > Engine tune-ups or other routine maintenance items or any normally scheduled preventive maintenance or maintenance services as explained in the Operation and Maintenance Manual, including, but not limited to, valve lash adjustments, with special attention to the scheduled maintenance items including filters, fuel nozzles, fuel injectors, thermostats, seals and gaskets;
- > Storage or miscellaneous shop supplies
- > Steel shims and cast iron block inserts
- > Clamps and other fasteners not specified in Section XIV. COVERED COMPONENTS
- > Any and all "mechanical breakdowns" of failures that are covered under any "warranty" whether enforceable or not
- > Parts shipping charges and service charges unless provided by coverage type as described in Section XV. ADDITIONAL COVERAGE;
- > Any and all taxes
- > "Your" expenses from loss of time, inconvenience, downtime or downtime-related expenses, or other incidental or consequential loss to "you" that results from a "mechanical breakdown"

## IX. TRANSFER OR ASSIGNMENT OF EXTENDED SERVICE COVERAGE

*The remaining coverage of the Contract may be transferred or assigned to subsequent owners during the "coverage period" at no extra charge. To complete coverage transfer, the new owner of the "covered equipment" must present a copy of the current Registration Certificate to "us" within thirty (30) days, along with evidence of the transfer of the "covered equipment's" title. If in "our" opinion the new owner will operate the "covered equipment" in accordance with Section V. YOUR RESPONSIBILITIES, "we" will approve the transfer or assignment of the remaining coverage.*



## X. TERMINATIONS AND REFUNDS

Cancellation by "You". "You" may cancel this Contract by providing written notice to "us" of "your" intent to cancel. Cancellation will be effective on the date "we" receive the cancellation notice.

Refund and Administration Fee. If "you" cancel this Contract by returning it to "us" within ten (10) days of the signature date as indicated on the bottom of the Registration Certificate, "your" refund shall be the Coverage Fees less any claims paid and a \$125.00 administration fee.

If "you" cancel this Contract by returning it to "us" more than ten (10) days after the signature date, as indicated on the bottom of the Registration Certificate, the pro-rated refund will be based on the lesser of months or hours of unused coverage less any claims paid and a \$125 administration fee. No refund is available if coverage is transferred or assigned to a subsequent owner. A ten percent (10%) penalty shall be added to the refund if not paid within thirty (30) days from the time this Contract was returned to "us".

Cancellation by "Us". "We" may cancel this Contract and return to "you" the pro-rated refund based on the lesser of months or hours of unused coverage less any claims paid and a \$125.00 administration fee for the following reasons: the coverage fee for this Contract has not been paid by "you", the manufacturer's "warranty" has been cancelled or voided, or a substantial breach of duties by "you" relating to the "covered equipment" or its use.

If there is a material misrepresentation in the Registration Certificate, "we" may void this Contract without written notice and "you" will not be charged the Coverage Fee.

This Contract may be cancelled if the condition of an overhaul, as described in the definition of "coverage period" occurs. In the case of an overhaul occurring, the customer may receive residual contract value as calculated above and applied to the continuation of coverage under the Overhaul Protection Contract (OPC) for Cat Commercial Engines. The new term of coverage under the OPC program may be selected per available terms if OPC eligibility requirements have been met.

## XI. DISCLAIMERS

> **"OUR" RESPONSIBILITIES AND "YOUR" REMEDIES UNDER THIS CONTRACT ARE LIMITED TO THE PROVISIONS AS SPECIFIED HEREIN.**

> **"WE" DISCLAIM ANY EXPRESSED OR IMPLIED "WARRANTIES" IN CONNECTION HERewith INCLUDING ANY "WARRANTY" OF MERCHANTABILITY OR FITNESS FOR A PARTICULAR PURPOSE.**

> **"WE" ARE NOT RESPONSIBLE FOR INCIDENTAL OR CONSEQUENTIAL DAMAGES.**

> **REPLACEMENT PARTS FURNISHED UNDER THE TERMS OF THIS EXTENDED SERVICE COVERAGE CONTRACT ARE COVERED UNDER THE APPLICABLE REPLACEMENT PARTS "WARRANTY".**

> **THIS CONTRACT DOES NOT SUPERCEDE THE EMISSION WARRANTY FOR EMISSION RELATED COMPONENTS.**

> **MISREPRESENTATION OF THE COVERED EQUIPMENT'S ELIGIBILITY FOR EXTENDED SERVICE COVERAGE, OR THE ACTUAL ACCUMULATED MILES, KILOMETERS, HOURS, FUEL BURN OR AGE SHALL RESULT IN CANCELLATION OF THIS CONTRACT BY US.**

> **"WE" SHALL BE ENTITLED TO ALL OTHER REMEDIES.**

## XII. CUSTOMER ASSISTANCE

For the U.S. and Canada, when a problem arises concerning the operation of "your" "covered equipment" or concerning the service of "your" "covered equipment", the problem will normally be managed by the Cat or "authorized dealer" in "your" area.

"Your" satisfaction is a primary concern of Caterpillar and Cat dealers. If "you" have a problem that has not been handled to "your" complete satisfaction, follow these steps:

1. Discuss "your" problem with a manager from the "authorized dealership".
2. If "your" problem cannot be resolved at the Cat or "authorized dealer" without additional assistance, use this phone number to talk with a Customer Interaction Center Field Service Coordinator: 1-800-447-4986.

The normal hours are from 7:00 AM to 4:30 PM Monday through Friday, Central Time, USA. Please keep in mind the ultimate goal is to solve "your" problem at the "authorized dealership". Please follow the steps in sequence when a problem is experienced.

For outside the U.S.A., if a problem arises concerning the operation of "your" "covered equipment" or the service of "your" "covered equipment", please contact "your" nearest Cat dealer or Service Representative.

### XIII. PRIVACY NOTICE

"We" do not disclose any non-public personal information about "you" or former customers to anyone, except as permitted by law.

"We" may collect non-public personal information necessary for service contract coverage to "you" from the following sources:

- > Information that "we" receive from you on registrations, applications or other forms, such as "your" name, address, assets and income.
- > Information about "your" transactions with "us", "our" subsidiaries, "our" affiliates (received only with "your" express consent); and
- > Information from a customer reporting agency.

"We" restrict access to non public personal information about "you" to those employees who need to know that information to provide "ESC" services to "you".

"We" maintain physical, electronic, and procedural safeguards that comply with federal regulations to guard "your" non public personal information.

"Our" Privacy Statement is available upon request by contacting "your" local Cat dealer or "ESC" program manager.

### XIV. COVERED COMPONENTS

Major items that are serialized with unique model nomenclature; such as switchgear, automatic transfer switches or uninterruptible power supplies require a separate contract. Original Equipment Manufacturers' components made a part of the Caterpillar factory 'as-shipped' consist of the genset through the Design to Order (DTO) process are not covered unless Caterpillar has given prior written approval to include the OEM components in the coverage. Power module and rental power units coverage EXCLUDES enclosures, containers, undercarriage, ladders, lights, wheels, axles, brakes, tires, sound attenuation, sound reduction material, insulation, stabilizing jacks, fire suppression, and fire extinguishers.

**Platinum Level Coverage Components:** All as-shipped consist from the factory with Cat part numbers excluding filters, fluids, veebelts, hoses, power take-offs, paint, batteries, and clutches. Components associated with and contingent damage from the "DPF" and "SCR" are excluded unless "DPF" and "SCR" component coverage is purchased. Includes diesel oxidation catalysts (DOC) only (no "DPF" or "SCR"). The explanation above of OEM components and DTO orders coverage applies.

**Platinum Plus Level Coverage Components:** All as-shipped consist from the factory with Cat part numbers excluding filters, fluids, vee-belts, hoses, power take-offs, paint, batteries and clutches, plus additional Cat components, having a Cat part number, installed by an "authorized dealership" and accepted by "us" through the Platinum Plus Additional Coverage Component List and Approval Verification form, LEYH0001. Components associated with and contingent damage from the "DPF" and "SCR" are excluded unless "DPF" and "SCR" component coverage is purchased. Includes diesel oxidation catalysts (DOC) only (no "DPF" or "SCR").

#### **Crane and Rigging Allowance for Standby Applications:**

**Standby Platinum Plus Level Coverage:** Additional allowance for crane and rigging expense is granted if repairs cannot be completed within 48 hours of the "authorized dealer" technician's initial visit for the covered "mechanical breakdown" due solely to the nature of the "mechanical breakdown" or Cat's inability to supply the required repair components. The allowance for crane and rigging expenses is covered only if the crane and rigging is required to more cost effectively access the failed unit to perform covered repairs.

- > For Cat gensets with engines less than 7.5 liters displacement, the dollar allowance is \$1,000 (USD).
- > For Cat gensets with engines greater than or equal to 7.5 liters and up to 34 liters displacement, the dollar allowance is \$5,000 (USD).
- > For Cat gensets with engines greater than 34 liter displacement, the dollar allowance is \$12,500 (USD).

The explanation above of OEM components and DTO orders coverage applies. It is the responsibility of the "authorized dealer" to provide the following documents to Caterpillar;

- 1) A copy of the Extended Service Coverage Registration form, and
- 2) A list of Caterpillar components complete with the Cat part numbers.

These documents will become part of the permanent service history of the "covered equipment". Refer to Section XV for Additional Coverage for Platinum and Platinum Plus level Extended Service Coverage.

"Aftertreatment" component coverage is optional and additional to the base Tier 4 Stage IIIB or IV engine coverage and is for the specified system. "DPF" and "SCR" coverage is the same for Silver, Gold, Platinum, and Platinum Plus. Travel time and mileage will be based on the engine coverage. "DPF" and "SCR" component coverage must be ordered with the engine coverage and will have the same start and end date as the engine coverage. Coverage should be combined to cover engines equipped with both "DPF" and "SCR".

**"DPF" Component Coverage:** "DPF" filter/diesel oxidation catalysts and housing Radio frequency antennas and back pressure sensors Regeneration system, "DPF" related electronic components, Consumable and normal ware items are excluded (clamps, catalyst and filter substrate, etc.), AND Filter cleaning is excluded.

**"SCR" Component Coverage:** Components associated with and included in the as shipped original engine consist to include but not limited to: "SCR" catalyst, AMOX catalysts, reactor housing, and mixing pipe Urea based diesel emission fluid injection system to include, hoses, nozzle or injector, pump, and tank NOx and temperature sensors, "SCR" related electronic components, and Consumable and normal wear items are excluded (fluids, clamps, catalyst substrate, etc.)

## XV. ADDITIONAL COVERAGE

### Travel & Mileage Limitations:

For gensets up to 4 liters displacement and registered in Silver, Gold or Platinum Level Coverage,  
> Up to 2 hours and 100 miles / 162 kilometers travel allowance.

For gensets over 4 liters displacement and up to 7.5 liters displacement registered in Silver, Gold or Platinum Level Coverage,  
> Up to 4 hours and 200 miles / 325 kilometers travel allowance.

For gensets over 7.5 liters displacement and registered in Silver, Gold or Platinum Level Coverage,  
> Up to 8 hours and 320 miles / 515 kilometers travel allowance.

For gensets, regardless of displacement and registered in Platinum Plus,  
> Up to 10 hours and 500 miles / 802 kilometers travel allowance.

### Overtime Allowance:

For gensets registered in Platinum Plus level coverage, up to \$1500 of overtime labor may be claimed for the incremental cost of performing the repair outside of normal business hours. Incremental labor cost hours must be in consecutive shifts to standard labor hours. This allowance modifies Section IV. "OUR" RESPONSIBILITIES, regarding repairs being done during normal business hours. This allowance is payable when it is not reasonably practical for the covered repair to be completed during normal business hours.

### Emergency Freight:

Up to \$500 in emergency freight shipping charges through "our" recommended method, if the failed "covered components" require emergency shipping to expedite the repair or replacement of "covered components".

### Rental Allowance for Standby Applications:

#### Standby Platinum Level Coverage:

Additional allowance is granted if repairs cannot be completed within 96 hours of the "authorized dealer" technician's initial visit for the covered "mechanical breakdown" due solely to the nature of the "mechanical breakdown" or Cat's inability to supply the required repair components. The dollar allowance for Rental Genset expenses, from an "authorized dealer" is defined as the reasonable and customary rental charge, mileage and the necessary labor for connection and disconnection to "your" facility of the Rental Genset from the closest "authorized dealer".

- > For Cat gensets up to 4 liters, the maximum dollar allowance is \$2,500 (USD).
- > For Cat gensets greater than 4 liters and up to 7.5 liters displacement the maximum dollar allowance is \$5,000 (USD).
- > For Cat gensets greater than 7.5 liters and up to 34 liters displacement, the maximum dollar allowance is \$10,000 (USD).
- > For Cat gensets greater than 34 liters displacement, the maximum dollar allowance is \$15,000 (USD).

#### Standby Platinum Plus Level Coverage:

Additional coverage is granted if repairs cannot be completed within 48 hours of the "authorized dealer" technician's initial visit for the covered "mechanical breakdown" due solely to the nature of the "mechanical breakdown" or Cat's inability to supply the required repair components. The dollar allowance for Rental Genset expenses from and "authorized dealer" is defined as the reasonable and customary rental charge, mileage, and the necessary labor for connection and disconnection to "your" facility of the Rental Genset from the closest "authorized dealer".

- > For Cat gensets up to 4 liters, the maximum allowance is \$5,000 (USD).
- > For Cat gensets greater than 4 liters and up to 7.5 liters displacement the maximum dollar allowance is \$10,000 (USD).
- > For Cat gensets greater than 7.5 liters and up to 34 liters displacement, the maximum dollar allowance is \$20,000 (USD).
- > For Cat gensets greater than 34 liters displacement, the maximum dollar allowance is \$40,000 (USD).

## XVI. EXTENDED SERVICE COVERAGE CONDITIONS New "ESC" Eligibility Requirements:

For generator sets in prime or standby applications, with or without a known delivery date, the eligibility period ends on the last day of the standard Caterpillar warranty period. A late fee is added to units registering more than 365 days after the delivery date as recorded in SIMSi.

**New "ESC" hours of use limits:** In addition to the general hour limits described below, certain other factors may limit the maximum hours of use during the "coverage period". These factors include, but are not limited to, fuel quality, altitude of operation and other conditions of application severity. Generator sets in Standby Applications shall not exceed 500 hours per year during the "coverage period" and shall not exceed 10 years from the "delivery date" of the "covered equipment". Generator sets in all other applications shall not exceed the following limits based on engine displacement.

### Advantage "ESC" Eligibility Requirements for Standby Applications:

- 1) Initial registration, "upgrade or coverage continuation" requirements. The "covered equipment" must:
  - a) Be less than four (4) years from delivery date and accumulated less than 3,000 hours total use,
  - b) Be currently enrolled in a New "ESC" or Advantage "ESC" program and be less than 10 years since the build date of the "covered equipment", or
  - c) Be currently covered by an "authorized dealer" Customer Support Agreement (CSA) that ensures all preventative maintenance items are completed at the intervals described in the Operations and Maintenance Manual for the "covered equipment", prior to registration and be less than 10 years since the build date of the "covered equipment", or
  - d) Successfully complete an Advantage inspection by an "authorized dealer" - **reference form LEEE3239.**

**XVI. EXTENDED SERVICE COVERAGE CONDITIONS New "ESC" Eligibility Requirements: cont'd**

- 2) Age and hours of use limits. The equipment must be less than 25 years from the delivery date when the "coverage period" expires. Additionally, the total number of hours from delivery date (Advantage "ESC" coverage hours stated on the Registration Certificate plus total hours of operation prior to registration) cannot exceed the following hour limits based on engine displacement:
  - > 6,000 hours for less than 4 liters displacement,
  - > 8,000 hours for displacement equal to or more than 4 liters and less than 7.5 liters,
  - > 10,000 hours for displacement equal to or more than 7.5 liters and less than 22 liters,
  - > 15,000 hours for displacement equal to or more than 22 liters and less than 34 liters,
  - > 25,000 hours for displacement equal to or more than 34 liters.
- 3) During the coverage period: An "authorized dealer" CSA that ensures all preventive maintenance items are completed at the intervals described in the Operations and Maintenance Manual for the "covered equipment" is required for the duration of the "ESC" for contract eligibility.

**Advantage "ESC" Eligibility Requirements for Prime Applications:**

- 1) Initial registration, "upgrade or coverage continuation" requirements. The "covered equipment" must:
  - a) Be less than four (4) years from delivery date and accumulated less than 3,000 hours total use since new, or
  - b) Be currently enrolled in a New "ESC" or Advantage "ESC" program and be less than 10 years since the build date of the "covered equipment", or
  - c) Have successfully completed an Advantage inspection by an "authorized dealer" - **reference form LEEE3239.**
- 2) Age and hours of use limits: To qualify for Advantage "ESC" for Prime applications, the generator set must be less than 10 years from the delivery date when the "coverage period" expires. Additionally, the total number of hours from delivery date (Advantage "ESC" coverage hours stated on the Registration Certificate plus total hours prior to registration) cannot exceed the following hour limits based on engine displacement:
  - > 6,000 hours for less than 4 liter displacement,
  - > 8,000 hours for displacement equal to or greater than 4 liters and less than 7.5 liters,
  - > 10,000 hours for displacement equal to or greater than 7.5 liters and less than 22 liters,
  - > 15,000 hours for displacement equal to or greater than 22 liters and less than 34 liters,
  - > 25,000 hours for displacement equal to or greater than 34 liters.
- 3) During the coverage period: All "covered components" must pass inspection or be replaced at the proper intervals as prescribed in the manufacturer's Operation and Maintenance Manual by an "authorized dealer" to qualify for continued coverage under this "ESC" Contract.

**"Your" failure to follow the manufacturer's Operation and Maintenance Manual may result in denial of claims.**

**XVII. PROVIDER**

**In the United States and its territories of Guam, America Samoa, the Northern Mariana Islands and U.S. Minor Outlying Islands:** The Provider of this service contract is Caterpillar, Inc.

**In Canada excluding Alberta:** The Provider of this service contract is the Cat Dealer.

**In Alberta, Canada:** The Provider of this service contract is Caterpillar of Canada.

**In All Other Countries and the U.S. territories of Puerto Rico and the U.S. Virgin Islands:** The Provider of this service contract is the Cat Dealer.

**XVIII. NOTICE FOR U.S.A. CONTRACTS ONLY**

Obligations of the Provider under this Contract are backed only by the full faith and credit of the Provider (issuer) and are not guaranteed under a service contract reimbursement insurance policy.

All "covered components" must pass inspection or be replaced at the proper intervals as prescribed in the manufacturer's Operation and Maintenance Manual by an "Authorized Dealer" to qualify for continued coverage under this "ESC" Contract. "Your" failure to follow the manufacturer's Operation and Maintenance Manual may result in denial of claims.

**XVIII. ENDORSEMENTS, APPLICABLE TO U.S.A. ISSUED CONTRACTS ONLY**

**In Georgia: Paragraph X. TERMINATIONS AND REFUNDS** the subparagraphs Refund and Administration Fee and Cancellation by Us are replaced by the following:

- > **Refund and Administration Fee.** If "you" cancel this Contract, the pro-rated refund will be based upon the lesser of months, miles or hours of unused coverage provided.
- > **Cancellation by Us.** We may only cancel this Contract for fraud, material misrepresentation or non-payment. If "we" cancel this Contract, "we" will give written notice of cancellation at least:
  - a) 10 days before the effective date of cancellation if we cancel for nonpayment of coverage fees or,
  - b) 30 days before the effective date of cancellation if we cancel for any other reason. The pro-rated refund will be based upon the lesser of months, miles or hours of unused coverage provided.

**XVIII. ENDORSEMENTS, APPLICABLE TO U.S.A. ISSUED CONTRACTS ONLY cont'd**

**In Hawaii:** Paragraph X. **TERMINATIONS AND REFUNDS**, the subparagraph Cancellation by Us is replaced by the following:

- > **Cancellation by Us.** "We" may cancel this Contract and return to "you" the pro-rated refund based on the lesser of months, miles or hours of unused coverage provided less any claims paid and a \$35.00 administration fee without notice for nonpayment or the Coverage Fee, material misrepresentation or substantial breach of "your" duties relating to "covered equipment" and with five (5) days prior notice of cancellation that states the effective date of cancellation for any other reason.

**In Hawaii and Wyoming:** Paragraph X. **TERMINATIONS AND REFUNDS**, the subparagraph Refund and Administration Fee is replaced by the following:

- > **Refund and Administration Fee.** If no claims have been made under the Contract delivered at the time of sale and "you" cancel this Contract by returning it to "us" within twenty (20) days of purchase, "your" refund shall be the Coverage Fees, or between twenty (20) and thirty (30) days of purchase, "your" refund shall be the Coverage Fees less a \$25.00 administration fee. If "you" cancel this Contract by returning it to "us" after thirty (30) days from purchase, the pro-rated refund will be based on the lesser of months, miles or hours of unused coverage provided less any claims paid and a \$25.00 administration fee. No refund is available if coverage is transferred or assigned to a subsequent owner. A ten percent (10%) penalty shall be added to the refund if not paid within thirty (30) days from the time this Contract was returned to "us".

**In Wisconsin:** Paragraph X. **TERMINATION AND REFUNDS** the subparagraphs Refund and Administration Fee and Cancellation by Us are replaced by the following:

- > **Refund and Administration Fee.** If "you" cancel this Contract by returning it to "us" within fifteen (15) days after "you" receive this Contract, "your" refund shall be the Coverage Fees less a \$35.00 administration fee. If "you" cancel this Contract by returning it to "us" after fifteen (15) days from the date "you" receive the Contract, the pro-rated refund will be based on the lesser of months, miles or hours of unused coverage provided less a \$35.00 administration fee. If "we" cancel this Contract, "we" will provide "you" with written notice and "we" will not deduct any claims paid from "your" refund. A ten percent (10%) penalty shall be added to the refund if not paid within thirty (30) days from the time this Contract was returned to "us". All other terms and conditions apply.
- > **Cancellation by Us.** "We" may cancel this Contract with written notice to "you" and return to "you" the pro-rated refund based on the lesser of months, miles or hours of unused coverage provided and a \$25.00 administration fee for the following reasons: the coverage fee for this Contract has not been paid by "you", the manufacturer's warranty has been canceled or voided, or a substantial breach of duties by "you" relating to the "covered equipment" or its use. If there is a material misrepresentation with intent to deceive by "you" in the Registration Certificate, "we" may void this Contract with written notice and "you" will not be charged the Coverage Fee.

**"THIS WARRANTY IS SUBJECT TO LIMITED REGULATION BY THE OFFICE OF THE COMMISSIONER OF INSURANCE."**

**GENERATOR SET OR ENGINE COMPONENT  
EXTENDED SERVICE COVERAGE MATRIX  
Effective January 1, 2015**

Coverage Items	Silver	Gold	Coverage Items	Silver	Gold
<b>COOLING SYSTEM</b>			<b>AIR INDUCTION &amp; EXHAUST</b>		
Thermostat Housing	Yes	Yes	Exhaust Manifolds, Studs & Gaskets	Yes	Yes
Water Manifold Housing	Yes	Yes	Inlet Air Heater Relay	Yes	Yes
Jacket Water Pre-cooler	Yes	Yes	Intake Manifold	Yes	Yes
Jacket Water Pump	No	Yes	Turbocharger (mounting hardware, lines, wastegate)	No	Yes
<b>FUEL SYSTEM</b>			<b>SHORT BLOCK</b>		
Steel and Stainless Steel Fuel Lines	Yes	Yes	Cylinder Block Casting	Yes	Yes
Fuel Shutoff Solenoid (diesel only)	Yes	Yes	Freeze Plugs	Yes	Yes
Fuel Injectors (diesel only)	No	Yes	Crankshaft	Yes	Yes
Spark Plug Extension (gas only)	Yes	Yes	Crankshaft Rod, Main and Thrust Bearings	Yes	Yes
Ignition Transformer (gas only)	Yes	Yes	Connecting Rod Assembly	Yes	Yes
Throttle (gas only)	Yes	Yes	Piston, Wrist Pin, Retainer clip & Piston Rings	Yes	Yes
<b>LUBRICATION SYSTEM</b>			Piston Cooling Jets	Yes	Yes
Oil Pan	Yes	Yes	Cylinder Liners, Seals & Filler Band	Yes	Yes
Engine Oil Pump	Yes	Yes	Main Bearing Cap Bolts	Yes	Yes
Oil Cooler Housing & Core/Bonnet	Yes	Yes	<b>CYLINDER HEAD</b>		
Oil Filter Base	Yes	Yes	Cylinder Head Casting, Sleeves, Bolts & Gaskets	Yes	Yes
<b>ELECTRICAL SYSTEM</b>			Freeze Plug	Yes	Yes
ITSM (gas only)	Yes	Yes	Spacer Plate & Spacer Plate Gasket	Yes	Yes
Control Module (ECM)	Yes	Yes	Intake & Exhaust Valve (all related parts)	Yes	Yes
Sensors: All Engine Sensors	Yes	Yes	Roller Follower	Yes	Yes
<b>FRONT &amp; REAR COVERS</b>			Valve Mechanism, Rocker Arm, Brackets, Push Tube	Yes	Yes
Front Covers / Plate / Housing / Gears (& Gaskets)	Yes	Yes	Bridge Dowels, Adjusting Screws, Nuts & Shaft	Yes	Yes
Vibration Damper	Yes	Yes	Valve Cover & Base	Yes	Yes
Flywheel Housing & Gasket	Yes	Yes	Camshaft, Camshaft Bearings, Key, Gear	Yes	Yes
<b>ALTERNATOR END</b>			Camshaft Rear Cover / Seal	Yes	Yes
Alternator (including rotor, stator, exciter, bearings & coupling)	Yes	Yes	<b>MISCELLANEOUS</b>		
Generator Controls (including EMCP, Operator Interface Mounted on Generator)	No	Yes	Cat Bolts Attaching Covered Components	Yes	Yes
Power Center (Circuit Breakers, Voltage Regulators, Bus Bar)	No	Yes			

**Note:** components not specifically listed in the coverage matrix are not covered under Silver or Gold level coverage options.



Randy Taylor <rdtaylor@chattanooga.gov>

---

## 1.5 MW Generator

---

Andy Downs <adowns@stowerscat.com>

Thu, May 24, 2018 at 12:56 PM

To: Jim Spence <jspence@chattanooga.gov>

Cc: Matt Hagy <mhagy@stowerscat.com>, Randy Taylor <rdtaylor@chattanooga.gov>

We would be able to do a complete inspection of trailer during our inspection that we have to do for Cat to apply for the advantage warranty. Will you be able to send a P.O. that is contingent on that warranty being applied to the unit? Once we get the P.O. we will perform all inspections and load bank to get warranty.

Sent from my iPhone

[Quoted text hidden]



# City of Chattanooga

Mayor Andy Berke

May 30, 2018

Mr. Justin Holland  
Administrator, Public Works Department  
Waste Resources Division  
1250 Market Street, Suite 2100  
Chattanooga, TN 37402

Subject: 167759 / 305063 – Sewer Pipes & Fittings – Waste Resources Division –  
Public Works Department

Dear Mr. Holland:

Council approval is recommended to issue a purchase order for the purchase of Sewer Pipes & Fittings for Waste Resources Division, Public Works Department.

The invitation to bid was sent to eight (8) vendors as well as formally advertised. Four (4) responses were received as shown below and on the attachment. Copies of the bids are retained on file and available for review in the Purchasing Office upon request.

<u>Bidder</u>	<u>Bid</u>
Piping Supply Company	\$ 407,280.92
Hayes Pipe Supply, Inc	\$ 437,638.88
Consolidated Pipe & Supply Company, Inc	\$ 473,618.98
C & B Piping, Inc	\$ 524,843.94

I recommend awarding this purchase to Piping Supply Company, 3008 N. Hickory Street, Chattanooga, TN 37406, who offers the best value bid which meets the specifications for the City of Chattanooga, in the amount of \$407,280.92.

Respectfully yours,

Bonnie Woodward  
Director of Purchasing

BW/mlm

Attachments



Item #	Item	Piping Supply Unit Price	Consolidated Pipe & Supply Unit Price	C & B Piping Unit Price	Hayes Pipe Supply Unit Price
<b>Pipe</b>					
1	54 IN CL250 DI Pipe	\$ 38,279.00	\$ 51,873.48	\$ 47,518.80	\$ 52,380.00
2	48 IN CL250 DI Pipe	\$ 31,129.00	\$ 40,496.76	\$ 38,269.20	\$ 35,640.00
3	42 IN CL250 DI Pipe	\$ 24,075.00	\$ 31,881.60	\$ 23,539.68	\$ 26,460.00
4	30 IN CL250 DI Pipe	\$ 14,200.00	\$ 12,385.44	\$ 14,398.56	\$ 15,422.40
5	24 IN CL250 DI Pipe	\$ 9,048.00	\$ 9,093.60	\$ 10,592.88	\$ 8,964.00
6	20 IN CL250 DI Pipe	\$ 6,669.00	\$ 7,349.40	\$ 7,887.36	\$ 6,647.40
7	16 IN CL250 DI Pipe	\$ 4,845.00	\$ 4,957.20	\$ 5,682.48	\$ 4,843.80
8	14 IN CL250 DI Pipe	\$ 4,027.00	\$ 4,114.80	\$ 4,716.42	\$ 4,033.80
9	12 IN C900 PVC DR18	\$ 1,543.00	\$ 1,505.00	\$ 2,292.84	\$ 1,620.00
10	10 IN C900 PVC DR18	\$ 1,093.00	\$ 1,066.00	\$ 1,543.32	\$ 1,153.44
11	8 IN C900 PVC DR18	\$ 728.00	\$ 710.00	\$ 1,081.08	\$ 766.80
12	6 IN C900 PVC DR18	\$ 420.00	\$ 410.00	\$ 610.20	\$ 442.80
13	4 IN C900 PVC DR18	\$ 213.00	\$ 207.00	\$ 315.36	\$ 223.56
<b>MJ Sleeves</b>					
14	54 IN MJ Long SLV	\$ 6,480.00	\$ 10,640.00	\$ 13,167.47	\$ 6,612.60
15	48 IN MJ Long SLV	\$ 3,904.92	\$ 3,996.00	\$ 5,173.00	\$ 3,983.74
16	42 IN MJ Long SLV	\$ 2,779.86	\$ 2,840.00	\$ 3,682.70	\$ 2,835.96
17	30 IN MJ Long SLV	\$ 1,480.18	\$ 1,500.00	\$ 1,961.40	\$ 1,510.06
18	24 IN MJ Long SLV	\$ 706.64	\$ 760.00	\$ 936.60	\$ 728.54
19	20 IN MJ Long SLV	\$ 536.80	\$ 580.00	\$ 711.20	\$ 553.42
20	16 IN MJ Long SLV	\$ 347.42	\$ 370.00	\$ 460.60	\$ 358.16
21	14 IN MJ Long SLV	\$ 346.60	\$ 288.00	\$ 364.00	\$ 283.12
22	12 IN MJ Long SLV	\$ 181.70	\$ 184.00	\$ 240.80	\$ 187.32
23	10 IN MJ Long SLV	\$ 134.34	\$ 136.00	\$ 178.50	\$ 138.50
24	8 IN MJ Long SLV	\$ 113.04	\$ 118.00	\$ 149.40	\$ 116.54
25	6 IN MJ Long SLV	\$ 69.24	\$ 70.40	\$ 92.40	\$ 71.38
26	4 IN MJ Long SLV	\$ 41.42	\$ 43.00	\$ 55.30	\$ 42.72
<b>MEGA LUG ACC</b>					
27	54 IN MEGALUG w/ACC EBAA	\$ 61,152.00	\$ 61,440.00	\$ 76,231.80	\$ 63,192.00
28	48 IN MEGALUG w/ACC EBAA	\$ 21,936.00	\$ 22,140.00	\$ 27,357.72	\$ 22,678.08
29	42 IN MEGALUG w/ACC EBAA	\$ 17,148.00	\$ 17,424.00	\$ 21,380.28	\$ 17,723.04
30	30 IN MEGALUG w/ACC EBAA	\$ 8,940.00	\$ 9,114.00	\$ 10,712.88	\$ 9,249.12
31	24 IN MEGALUG w/ACC EBAA	\$ 3,900.00	\$ 3,954.00	\$ 4,639.32	\$ 4,035.00
32	20 IN MEGALUG w/ACC EBAA	\$ 2,820.00	\$ 2,872.80	\$ 3,399.48	\$ 2,922.60
33	16 IN MEGALUG w/ACC EBAA	\$ 1,716.00	\$ 1,754.40	\$ 2,030.76	\$ 1,780.92
34	14 IN MEGALUG w/ACC EBAA	\$ 1,260.00	\$ 1,320.00	\$ 1,462.08	\$ 1,307.04
35	12 IN MEGALUG w/ACC EBAA PVC Bolt Kit	\$ 336.00	\$ 376.00	\$ 420.04	\$ 381.48

36	10 IN MEGALUG w/ACC EBAA PVC Bolt Kit	\$	248.00	\$	356.00	\$	400.00	\$	362.48
37	8 IN MEGALUG w/ACC EBAA PVC Bolt Kit	\$	172.00	\$	208.00	\$	227.56	\$	210.28
38	6 IN MEGALUG w/ACC EBAA PVC Bolt Kit	\$	128.00	\$	156.00	\$	163.32	\$	155.76
39	4 IN MEGALUG w/ACC EBAA PVC Bolt Kit	\$	104.00	\$	124.00	\$	129.28	\$	123.12
<b>Transition Fittings</b>									
40	4 x 2 DI TAP CAP	\$	40.84	\$	37.90	\$	53.20	\$	128.34
41	4 x 3 MJ Reducer	\$	45.00	\$	43.00	\$	53.20	\$	140.96
42	10 IN HDPE MJ ADPT	\$	290.00	\$	230.00	\$	1,000.00	\$	229.00
43	10 IN ADPT ACC Kit	\$	110.00	\$	76.00	\$	58.36	\$	76.50
<b>MJ 90's</b>									
44	54 IN MJ 90	\$	15,174.10	\$	24,380.00	\$	25,588.60	\$	15,480.32
45	48 IN MJ 90	\$	7,766.66	\$	7,820.00	\$	10,288.60	\$	7,923.40
46	42 IN MJ 90	\$	5,824.86	\$	5,860.00	\$	7,716.80	\$	5,942.40
47	30 IN MJ 90	\$	2,173.22	\$	2,150.00	\$	2,879.10	\$	2,217.08
48	24 IN MJ 90	\$	1,354.12	\$	1,498.00	\$	1,794.10	\$	1,396.04
49	20 IN MJ 90	\$	907.28	\$	1,020.00	\$	1,201.90	\$	935.38
50	18 IN MJ 90	\$	651.02	\$	710.00	\$	862.40	\$	671.18
51	16 IN MJ 90	\$	540.34	\$	592.00	\$	716.10	\$	557.08
52	14 IN MJ 90	\$	398.30	\$	428.00	\$	527.80	\$	410.64
53	12 IN MJ 90	\$	237.90	\$	260.00	\$	315.70	\$	245.28
54	10 IN MJ 90	\$	176.96	\$	188.00	\$	234.50	\$	182.44
55	8 IN MJ 90	\$	111.26	\$	118.00	\$	147.70	\$	114.72
56	6 IN MJ 90	\$	76.34	\$	78.00	\$	101.50	\$	78.72
57	4 IN MJ 90	\$	46.76	\$	50.00	\$	62.30	\$	48.20
<b>MJ 45's</b>									
58	54 IN MJ 45	\$	12,340.38	\$	18,200.00	\$	17,830.59	\$	12,589.42
59	48 IN MJ 45	\$	5,372.10	\$	5,340.00	\$	7,116.90	\$	5,480.52
60	42 IN MJ 45	\$	4,099.64	\$	4,058.00	\$	5,431.30	\$	4,182.38
61	30 IN MJ 45	\$	1,825.22	\$	1,820.00	\$	2,418.50	\$	1,881.74
62	24 IN MJ 45	\$	898.40	\$	950.00	\$	1,190.70	\$	926.22
63	20 IN MJ 45	\$	591.24	\$	640.00	\$	783.30	\$	609.54
64	18 IN MJ 45	\$	553.94	\$	596.00	\$	734.30	\$	571.10
65	16 IN MJ 45	\$	386.00	\$	408.00	\$	511.70	\$	397.82
66	14 IN MJ 45	\$	309.52	\$	336.00	\$	410.20	\$	319.12
67	12 IN MJ 45	\$	197.08	\$	212.00	\$	261.10	\$	203.18
68	10 IN MJ 45	\$	131.98	\$	140.00	\$	175.00	\$	136.06
69	8 IN MJ 45	\$	90.56	\$	99.00	\$	120.40	\$	93.36
70	6 IN MJ 45	\$	62.14	\$	66.00	\$	82.60	\$	64.06
71	4 IN MJ 45	\$	38.46	\$	39.20	\$	51.10	\$	39.66
<b>MJ Tee's</b>									
72	54 IN MJ Tee	\$	21,876.06	\$	32,240.00	\$	31,666.67	\$	22,317.52
73	48 IN MJ Tee	\$	10,398.58	\$	10,660.00	\$	13,775.30	\$	10,608.42

74	42 IN MJ Tee	\$	7,750.70	\$	7,860.00	\$	10,267.60	\$	7,907.10
75	30 IN MJ Tee	\$	3,142.66	\$	3,180.00	\$	4,163.60	\$	3,206.08
76	24 IN MJ Tee	\$	1,499.12	\$	1,510.00	\$	1,985.90	\$	1,544.06
77	20 IN MJ Tee	\$	1,010.26	\$	1,080.00	\$	1,338.40	\$	1,040.56
78	18 IN MJ Tee	\$	1,095.48	\$	1,160.00	\$	1,451.80	\$	1,128.34
79	16 IN MJ Tee	\$	757.54	\$	808.00	\$	1,003.80	\$	780.26
80	14 IN MJ Tee	\$	551.00	\$	580.00	\$	730.10	\$	567.52
81	12 IN MJ Tee	\$	331.42	\$	340.00	\$	439.60	\$	341.36
82	10 IN MJ Tee	\$	237.32	\$	250.00	\$	315.00	\$	244.44
83	8 IN MJ Tee	\$	166.30	\$	170.00	\$	220.50	\$	171.30
84	6 IN MJ Tee	\$	110.68	\$	120.00	\$	147.00	\$	114.00
85	4 IN MJ Tee	\$	61.54	\$	63.00	\$	81.90	\$	63.40
<b>MJ Solid Plugs</b>									
86	54 IN MJ Plug Solid	\$	4,971.42	\$	8,990.00	\$	9,273.33	\$	5,120.48
87	48 IN MJ Plug Solid	\$	3,560.48	\$	3,598.00	\$	4,716.60	\$	3,667.24
88	42 IN MJ Plug Solid	\$	2,670.96	\$	2,690.00	\$	3,538.50	\$	2,751.04
89	30 IN MJ Plug Solid	\$	1,246.40	\$	1,280.00	\$	1,651.30	\$	1,283.78
90	24 IN MJ Plug Solid	\$	627.92	\$	634.00	\$	832.30	\$	646.76
91	20 IN MJ Plug Solid	\$	452.76	\$	480.00	\$	599.90	\$	466.32
92	18 IN MJ Plug Solid	\$	344.44	\$	360.00	\$	456.40	\$	354.78
93	16 IN MJ Plug Solid	\$	277.56	\$	300.00	\$	368.20	\$	285.90
94	14 IN MJ Plug Solid	\$	217.20	\$	230.00	\$	288.40	\$	223.72
95	12 IN MJ Plug Solid	\$	104.76	\$	108.00	\$	139.30	\$	107.90
96	10 IN MJ Plug Solid	\$	106.52	\$	110.00	\$	141.40	\$	109.72
97	8 IN MJ Plug Solid	\$	60.94	\$	64.00	\$	81.20	\$	62.78
98	6 IN MJ Plug Solid	\$	40.82	\$	42.00	\$	54.60	\$	42.06
99	4 IN MJ Plug Solid	\$	21.30	\$	22.00	\$	28.70	\$	21.94
<b>Foster APDT</b>									
100	4 IN Foster ADPT	\$	116.00	\$	116.00	\$	199.86	\$	137.50
101	6 IN Foster ADPT	\$	146.00	\$	144.00	\$	253.20	\$	171.90
102	8 IN Foster ADPT	\$	220.00	\$	218.00	\$	346.54	\$	249.30
103	10 IN Foster ADPT	\$	330.00	\$	320.00	\$	493.20	\$	365.40
104	14 IN Foster ADPT	\$	616.00	\$	580.00	\$	826.54	\$	666.40
105	12 IN Foster ADPT	\$	340.00	\$	328.00	\$	546.54	\$	336.14
106	16 IN Foster ADPT	\$	666.00	\$	644.00	\$	893.20	\$	720.14
107	18 IN Foster ADPT	\$	850.00	\$	820.00	\$	1,133.20	\$	913.64
108	24 IN Foster ADPT	\$	1,370.00	\$	1,280.00	\$	1,813.20	\$	1,461.90
109	30 IN Foster ADPT	\$	2,024.00	\$	2,160.00	\$	2,666.54	\$	2,149.90
<b>UNI Flange's</b>									
110	4 IN UNI FLG	\$	46.00	\$	51.00	\$	61.68	\$	53.00
111	6 IN UNI FLG	\$	50.00	\$	53.00	\$	66.64	\$	57.00
112	8 IN UNI FLG	\$	68.00	\$	74.00	\$	92.24	\$	77.80

113	10 IN UNI FLG	\$	126.00	\$	136.00	\$	165.70	\$	142.78
114	14 IN UNI FLG	\$	400.00	\$	350.00	\$	439.46	\$	377.92
115	12 IN UNI FLG	\$	148.00	\$	158.00	\$	193.28	\$	166.54

**TOTAL:** \$407,280.92    \$473,618.98    \$524,843.94    \$437,638.88

Uncoated Pipe– Requisition 167759

Ferguson Waterworks  
910A Cobb Parkway  
Marietta, GA 30064

Consolidated Pipe & Supply Co.  
1332 Stuart Street  
Chattanooga, TN 37405

Walter A. Wood Supply  
P.O. Box 100  
Rossville, GA 30741

Piping Supply Co.  
3008 N Hickory Street  
Chattanooga, TN 37406

Hayes Pipe Supply  
3000 Industrial Pkwy East  
Knoxville, TN 37921

C&B Piping, Inc.  
8804 Parkway Dr.  
Leeds, AL 35097

Grainger Industrial Supply  
902 Creekside Dr.  
Chattanooga, TN 37406

Southern Pipe & Supply  
201 East 14th Street  
Columbia, TN 38401

# BID SOLICITATION



**City of Chattanooga**  
 101 East 11th Street, Suite G13  
 Chattanooga, TN 37402

**BID OPENING DATE AND TIME:**  
 19-APR-18 at 2:00 PM

**BID NUMBER: 305063**

**BUYER:**  
**PHONE #:** (423) 643-7230  
**DELIVERY REQUIRED:**

SEALED BIDS

Mail or submit two (2) signed copies of bid form to this office in the enclosed envelope. Retain one copy for your file.

V  
E  
N  
D  
O  
R

RFQ

M  
A  
I  
L  
I  
N  
G

City of Chattanooga  
 101 East 11th Street, Suite G13  
 Chattanooga, TN 37402

Item	Class-Item	Quantity	Unit	Unit Price	Total
Requisition No.: 167759 Ordering Dept.: Waste Resources Buyer: Geoffrey Hipp 423-643-7233 ..... DESCRIPTION: Uncoated Sewer Pipe per specifications ..... ATTACHMENTS: - Specifications - Iran Divestment Act - Affirmative Action Plan - Standard Terms and Conditions: ( <a href="http://www.chattanooga.gov/purchasing/standard-terms-and-conditions">http://www.chattanooga.gov/purchasing/standard-terms-and-conditions</a> ) ..... *** BIDS MUST BE RECEIVED NO LATER THAN *** ***** 2:00 PM ON APRIL 19, 2018 ***** ..... PLEASE SUBMIT BIDS IN DUPLICATE INDICATING BID NUMBER (305063) ON OUTSIDE PACKAGING ALL ITEMS MUST BE QUOTED F.O.B. DESTINATION, FREIGHT ALLOWED. ..... NOTE: All bids received are subject to the terms and conditions contained herein and as listed in the above referenced website. The undersigned Bidder acknowledges having received, reviewed, and agrees to be bound to these terms and conditions, unless specific written exceptions are otherwise stated.  The City of Chattanooga reserves the right to reject any and/or all bids, waive any informalities in the bids received, and to accept any bid which in its opinion may be for the best interest of the city.  The City of Chattanooga will be non-discriminatory in the purchase of all goods and services on the basis of race, color, or national origin. ..... PLEASE PROVIDE US WITH THE FOLLOWING INFORMATION: Company Name _____ Address _____ Phone/Toll-Free No. _____ Fax No. _____ E-Mail Address _____ Contact Person's Name _____ Estimated Delivery _____ Minority-Owned Business ___ Small Business ___ Veteran ___ Minority Woman Owned Business ___ Disabled Veteran ___ Women-Owned Business ___					

NOTE: ALL BIDS RECEIVED ARE SUBJECT TO THE TERMS AND CONDITIONS

ALL BIDS MUST BE SIGNED – The undersigned offers the above quoted prices under the conditions contained herein.

COMPANY: ROING SUPPLY CO

SIGNATURE: *Mitch Warren*

NAME AND TITLE: MITCH WARREN V.P.

The City is Exempt from all Federal and State Tax.  
 Bids will be received at the above mentioned address.

TERMS OF PAYMENT: NET 30

TELEPHONE NUMBER: 423 698 8996

# BID SOLICITATION



City of Chattanooga  
101 East 11th Street, Suite G13  
Chattanooga, TN 37402

**BID OPENING DATE AND TIME:**  
19-APR-18 at 2:00 PM

**BID NUMBER: 305063**

SEALED BIDS

Mail or submit two (2) signed copies of bid form to this office in the enclosed envelope. Retain one copy for your file.

**BUYER:**  
**PHONE #:** (423) 643-7230  
**DELIVERY REQUIRED:**

V  
E  
N  
D  
O  
R

RFQ

M  
A  
I  
L  
T  
O

City of Chattanooga  
101 East 11th Street, Suite G13  
Chattanooga, TN 37402

Item	Class-Item	Quantity	Unit	Unit Price	Total
1	54 IN CL250 DI PIPE <i>F/R</i>	<i>108</i> <i>100'</i>	Foot	<i>382.79</i>	<i>38,279.<sup>00</sup></i>
2	48IN CL250 DI PIPE <i>F/R</i>	<i>108</i> <i>100'</i>	Foot	<i>311.29</i>	<i>31,129.<sup>00</sup></i>
3	42IN CL250 DI PIPE <i>F/R</i>	<i>108</i> <i>100'</i>	Foot	<i>240.75</i>	<i>24,075.<sup>00</sup></i>
4	30IN CL250 DI PIPE <i>F/R</i>	<i>108</i> <i>100'</i>	Foot	<i>142.00</i>	<i>14,200.<sup>00</sup></i>
5	24IN CL250 DI PIPE <i>LOCK GASK.</i>	<i>108</i> <i>100'</i>	Foot	<i>90.48</i>	<i>9,048.<sup>00</sup></i>
6	20IN CL250 DI PIPE <i>LOCK GASK.</i>	<i>108</i> <i>100'</i>	Foot	<i>66.69</i>	<i>6,669.<sup>00</sup></i>
7	16IN CL250 DI PIPE <i>LOCK GASK.</i>	<i>108</i> <i>100'</i>	Foot	<i>48.45</i>	<i>4,845.<sup>00</sup></i>
8	14 IN CL250 DI PIPE <i>LOCK GASK.</i>	<i>108</i> <i>100'</i>	Foot	<i>40.27</i>	<i>4,027.<sup>00</sup></i>
9	12IN C900 PVC DR18	<i>108</i> <i>100'</i>	Foot	<i>15.43</i>	<i>1,543.<sup>00</sup></i>
10	10IN C900 PVC DR18	<i>108</i> <i>100'</i>	Foot	<i>10.93</i>	<i>1,093.<sup>00</sup></i>

NOTE: ALL BIDS RECEIVED ARE SUBJECT TO THE TERMS AND CONDITIONS

ALL BIDS MUST BE SIGNED - The undersigned offers the above quoted prices under the conditions contained herein.

The City is Exempt from all Federal and State Tax.  
Bids will be received at the above mentioned address.

COMPANY: *PIPING SPECIALTY CO*

TERMS OF PAYMENT: *NET 30*

SIGNATURE: *[Signature]*

TELEPHONE NUMBER: *423 698 8996*

NAME AND TITLE: *M. TECH WARRON V.P.*

# BID SOLICITATION



City of Chattanooga  
101 East 11th Street, Suite G13  
Chattanooga, TN 37402

**BID OPENING DATE AND TIME:**  
19-APR-18 at 2:00 PM  
**BID NUMBER:** 305063

**SEALED BIDS**  
Mail or submit two (2) signed copies of bid form to this office in the enclosed envelope. Retain one copy for your file.

**BUYER:**  
**PHONE #:** (423) 643-7230  
**DELIVERY REQUIRED:**

**VENDOR** RFQ

**MAIL TO**  
City of Chattanooga  
101 East 11th Street, Suite G13  
Chattanooga, TN 37402

Item	Class-Item	Quantity	Unit	Unit Price	Total
11	8IN C900 PVC DR18	108 <del>100</del>	Foot	<u>7.28</u>	<u>728.00</u>
12	6IN C900 PVC DR18	108 <del>100</del>	Foot	<u>4.20</u>	<u>420.00</u>
13	4IN C900 PVC DR18	108 <del>100</del>	Foot	<u>2.13</u>	<u>213.00</u>
14	54 IN MJ LONG SLV	2	Each	<u>3240.00</u>	<u>6480.00</u>
15	48 IN MJ LONG SLV	2	Each	<u>1952.46</u>	<u>3904.92</u>
16	42 IN MJ LONG SLV	2	Each	<u>1389.93</u>	<u>2779.86</u>
17	30 IN MJ LONG SLV	2	Each	<u>740.09</u>	<u>1480.18</u>
18	24 IN MJ LONG SLV	2	Each	<u>353.32</u>	<u>706.64</u>
19	20 IN MJ LONG SLV	2	Each	<u>268.40</u>	<u>536.80</u>
20	16IN MJ LONG SLV	2	Each	<u>173.71</u>	<u>347.42</u>

**NOTE: ALL BIDS RECEIVED ARE SUBJECT TO THE TERMS AND CONDITIONS**

ALL BIDS MUST BE SIGNED - The undersigned offers the above quoted prices under the conditions contained herein.

The City is Exempt from all Federal and State Tax.  
Bids will be received at the above mentioned address.

COMPANY: PRINCE SUPPLY CO

TERMS OF PAYMENT: NET 30

SIGNATURE: [Signature]

TELEPHONE NUMBER: 423 698 8996

NAME AND TITLE: MITCH WARREN VP



# BID SOLICITATION



City of Chattanooga  
101 East 11th Street, Suite G13  
Chattanooga, TN 37402

**BID OPENING DATE AND TIME:**  
19-APR-18 at 2:00 PM

**BID NUMBER:** 305063

**BUYER:**  
**PHONE #:** (423) 643-7230  
**DELIVERY REQUIRED:**

SEALED BIDS

Mail or submit two (2) signed copies of bid form to this office in the enclosed envelope. Retain one copy for your file.

V  
E  
N  
D  
O  
R

RFQ

M  
A  
I  
L  
T  
O

City of Chattanooga  
101 East 11th Street, Suite G13  
Chattanooga, TN 37402

Item	Class-Item	Quantity	Unit	Unit Price	Total
21	14 IN MJ LONG SLV	2	Each	<u>173.30</u>	<u>346.60</u>
22	12IN MJ LONG SLV	2	Each	<u>90.85</u>	<u>181.70</u>
23	10IN MJ LONG SLV	2	Each	<u>67.17</u>	<u>134.34</u>
24	8IN MJ LONG SLV	2	Each	<u>56.52</u>	<u>113.04</u>
25	6IN MJ LONG SLV	2	Each	<u>34.62</u>	<u>69.24</u>
26	4IN MJ LONG SLV	2	Each	<u>20.71</u>	<u>41.42</u>
27	54IN MEGALUG W/ACC EBAA	12	Each	<u>5096<sup>00</sup></u>	<u>61152<sup>00</sup></u>
28	48IN MEGALUG W/ACC EBAA	12	Each	<u>1828<sup>00</sup></u>	<u>21936<sup>00</sup></u>
29	42IN MEGALUG W/ACC EBAA	12	Each	<u>1429<sup>00</sup></u>	<u>17148<sup>00</sup></u>
30	30IN MEGALUG W/ACC EBAA	12	Each	<u>745<sup>00</sup></u>	<u>8940<sup>00</sup></u>

NOTE: ALL BIDS RECEIVED ARE SUBJECT TO THE TERMS AND CONDITIONS

ALL BIDS MUST BE SIGNED - The undersigned offers the above quoted prices under the conditions contained herein.

The City is Exempt from all Federal and State Tax.  
Bids will be received at the above mentioned address.

TERMS OF PAYMENT: NET 30

TELEPHONE NUMBER: 423 698 8996

COMPANY: PIPING SUPPLY Co

SIGNATURE: Mitchell W...

NAME AND TITLE: MICHAEL WARRICK V.P.

# BID SOLICITATION



City of Chattanooga  
101 East 11th Street, Suite G13  
Chattanooga, TN 37402

**BID OPENING DATE AND TIME:**  
19-APR-18 at 2:00 PM  
**BID NUMBER: 305063**

SEALED BIDS

Mail or submit two (2) signed copies of bid form to this office in the enclosed envelope. Retain one copy for your file.

**BUYER:**  
**PHONE #:** (423) 643-7230  
**DELIVERY REQUIRED:**

V  
E  
N  
D  
O  
R

RFQ

M  
A  
J  
O  
R  
I  
T  
Y

City of Chattanooga  
101 East 11th Street, Suite G13  
Chattanooga, TN 37402

Item	Class-Item	Quantity	Unit	Unit Price	Total
31	24IN MEGALUG W/ ACC EBAA	12	Each	<u>325<sup>00</sup></u>	<u>3900<sup>00</sup></u>
32	20IN EBAA MEGALUG W/ ACC	12	Each	<u>235<sup>00</sup></u>	<u>2820<sup>00</sup></u>
33	16IN MEGALUG W/ACC EBAA	12	Each	<u>143<sup>00</sup></u>	<u>1716<sup>00</sup></u>
34	14IN MEGALUG W/ACC EBAA	12	Each	<u>105<sup>00</sup></u>	<u>1260<sup>00</sup></u>
35	12IN MEGALUG W/ACC EBAA PVC BOLT KIT	4	Each	<u>84<sup>00</sup></u>	<u>336<sup>00</sup></u>
36	10IN MEGALUG W/ACC EBAA PVC BOLT KIT	4	Each	<u>62<sup>00</sup></u>	<u>248<sup>00</sup></u>
37	8IN MEGALUG W/ACC EBAA PVC BOLT KIT	4	Each	<u>43<sup>00</sup></u>	<u>172<sup>00</sup></u>
38	6IN MEGALUG W/ACC EBAA PVC BOLT KIT	4	Each	<u>32<sup>00</sup></u>	<u>128<sup>00</sup></u>
39	4IN MEGALUG W/ACC EBAA PVC BOLT KIT	4	Each	<u>26<sup>00</sup></u>	<u>104<sup>00</sup></u>
40	4X2 DI TAP CAP	2	Each	<u>20.42</u>	<u>40.84</u>

NOTE: ALL BIDS RECEIVED ARE SUBJECT TO THE TERMS AND CONDITIONS

The City is Exempt from all Federal and State Tax.  
Bids will be received at the above mentioned address.

TERMS OF PAYMENT: NST 30

TELEPHONE NUMBER: 423 688 8996

ALL BIDS MUST BE SIGNED – The undersigned offers the above quoted prices under the conditions contained herein.

COMPANY: PIPING SUPPLY CO

SIGNATURE: [Signature]

NAME AND TITLE: ALICE WARREN V.P.

# BID SOLICITATION



City of Chattanooga  
101 East 11th Street, Suite G13  
Chattanooga, TN 37402

**BID OPENING DATE AND TIME:**  
19-APR-18 at 2:00 PM

**BID NUMBER: 305063**

---

**BUYER:**  
**PHONE #: (423) 643-7230**  
**DELIVERY REQUIRED:**

SEALED BIDS

Mail or submit two (2) signed copies of bid form to this office in the enclosed envelope. Retain one copy for your file.

V  
E  
N  
D  
O  
R

RFQ

M  
A  
I  
L  
T  
O

City of Chattanooga  
101 East 11th Street, Suite G13  
Chattanooga, TN 37402

Item	Class-Item	Quantity	Unit	Unit Price	Total
41	4X3 MJ REDUCER	2	Each	<u>22.50</u>	<u>45.00</u>
42	10IN HDPE MJ ADPT	2	Each	<u>145.00</u>	<u>290.00</u>
43	10IN MJ ADPT ACC KIT	2	Each	<u>55.00</u>	<u>110.00</u>
44	54IN MJ 90	2	Each	<u>7,587.05</u>	<u>15,174.10</u>
45	48IN MJ 90	2	Each	<u>3,883.33</u>	<u>7,766.66</u>
46	42IN MJ 90	2	Each	<u>2,912.43</u>	<u>5,824.86</u>
47	30IN MJ 90	2	Each	<u>1,086.61</u>	<u>2,173.22</u>
48	24IN MJ 90	2	Each	<u>677.06</u>	<u>1,354.12</u>
49	20IN MJ 90	2	Each	<u>453.64</u>	<u>907.28</u>
50	18IN MJ 90	2	Each	<u>325.51</u>	<u>651.02</u>

NOTE: ALL BIDS RECEIVED ARE SUBJECT TO THE TERMS AND CONDITIONS

ALL BIDS MUST BE SIGNED – The undersigned offers the above quoted prices under the conditions contained herein.

The City is Exempt from all Federal and State Tax.  
Bids will be received at the above mentioned address.

COMPANY: PIPING SUPPLY CO

TERMS OF PAYMENT: NET 30

SIGNATURE: [Signature]

TELEPHONE NUMBER: 423 698 8996

NAME AND TITLE: MITCH WARREN V.P.

# BID SOLICITATION



City of Chattanooga  
101 East 11th Street, Suite G13  
Chattanooga, TN 37402

<b>BID OPENING DATE AND TIME:</b> 19-APR-18 at 2:00 PM  <b>BID NUMBER: 305063</b>
<b>BUYER:</b> <b>PHONE #:</b> (423) 643-7230 <b>DELIVERY REQUIRED:</b>

SEALED BIDS

Mail or submit two (2) signed copies of bid form to this office in the enclosed envelope. Retain one copy for your file.

V  
E  
N  
D  
O  
R

RFQ

M  
A  
I  
L  
T  
O

City of Chattanooga  
101 East 11th Street, Suite G13  
Chattanooga, TN 37402

Item	Class-Item	Quantity	Unit	Unit Price	Total
51	16IN MJ 90	2	Each	<u>270.17</u>	<u>540.34</u>
52	14IN MJ 90	2	Each	<u>199.15</u>	<u>398.30</u>
53	12IN MJ 90	2	Each	<u>118.95</u>	<u>237.90</u>
54	10IN MJ 90	2	Each	<u>88.48</u>	<u>176.96</u>
55	8IN MJ 90	2	Each	<u>55.63</u>	<u>111.26</u>
56	6IN MJ 90	2	Each	<u>38.17</u>	<u>76.34</u>
57	4IN MJ 90	2	Each	<u>23.38</u>	<u>46.76</u>
58	54IN MJ 45	2	Each	<u>6,170.19</u>	<u>12,340.38</u>
59	48IN MJ 45	2	Each	<u>2,686.05</u>	<u>5,372.10</u>
60	42IN MJ 45	2	Each	<u>2,049.82</u>	<u>4,099.64</u>

NOTE: ALL BIDS RECEIVED ARE SUBJECT TO THE TERMS AND CONDITIONS

ALL BIDS MUST BE SIGNED – The undersigned offers the above quoted prices under the conditions contained herein.

The City is Exempt from all Federal and State Tax.  
Bids will be received at the above mentioned address.

TERMS OF PAYMENT: Net 30  
TELEPHONE NUMBER: 423 698 8996

COMPANY: PIPING COMPANY Co  
SIGNATURE: Mitch Warren  
NAME AND TITLE: Mitch Warren V P

# BID SOLICITATION



City of Chattanooga  
101 East 11th Street, Suite G13  
Chattanooga, TN 37402

**BID OPENING DATE AND TIME:**  
19-APR-18 at 2:00 PM

**BID NUMBER:** 305063

SEALED BIDS

Mail or submit two (2) signed copies of bid form to this office in the enclosed envelope. Retain one copy for your file.

**BUYER:**  
**PHONE #:** (423) 643-7230  
**DELIVERY REQUIRED:**

V  
E  
N  
D  
O  
R

RFQ

M  
A  
I  
L  
T  
O

City of Chattanooga  
101 East 11th Street, Suite G13  
Chattanooga, TN 37402

Item	Class-Item	Quantity	Unit	Unit Price	Total
61	30IN MJ 45	2	Each	<u>912.61</u>	<u>1,825.22</u>
62	24IN MJ 45	2	Each	<u>449.20</u>	<u>898.40</u>
63	20IN MJ 45	2	Each	<u>295.62</u>	<u>591.24</u>
64	18IN MJ 45	2	Each	<u>276.97</u>	<u>553.94</u>
65	16IN MJ 45	2	Each	<u>193.<sup>00</sup></u>	<u>386.<sup>00</sup></u>
66	14IN MJ 45	2	Each	<u>154.76</u>	<u>309.52</u>
67	12IN MJ 45	2	Each	<u>98.54</u>	<u>197.08</u>
68	10IN MJ 45	2	Each	<u>65.99</u>	<u>131.98</u>
69	8IN MJ 45	2	Each	<u>45.28</u>	<u>90.56</u>
70	6IN MJ 45	2	Each	<u>31.07</u>	<u>62.14</u>

NOTE: ALL BIDS RECEIVED ARE SUBJECT TO THE TERMS AND CONDITIONS

ALL BIDS MUST BE SIGNED - The undersigned offers the above quoted prices under the conditions contained herein.

The City is Exempt from all Federal and State Tax.  
Bids will be received at the above mentioned address.

COMPANY: PICING SUPPLY Co  
SIGNATURE: [Signature]  
NAME AND TITLE: Arturo Hernandez U.S.P.

TERMS OF PAYMENT: NET 30  
TELEPHONE NUMBER: 423 698 8896

# BID SOLICITATION



City of Chattanooga  
101 East 11th Street, Suite G13  
Chattanooga, TN 37402

**BID OPENING DATE AND TIME:**  
19-APR-18 at 2:00 PM

**BID NUMBER: 305063**

SEALED BIDS

Mail or submit two (2) signed copies of bid form to this office in the enclosed envelope. Retain one copy for your file.

**BUYER:**  
**PHONE #:** (423) 643-7230  
**DELIVERY REQUIRED:**

V  
E  
N  
D  
O  
R

RFQ

M  
A  
I  
L  
T  
O

City of Chattanooga  
101 East 11th Street, Suite G13  
Chattanooga, TN 37402

Item	Class-Item	Quantity	Unit	Unit Price	Total
71	4IN MJ 45	2	Each	<u>19.23</u>	<u>38.46</u>
72	54IN MJ TEE	2	Each	<u>10,938.03</u>	<u>21,876.06</u>
73	48IN MJ TEE	2	Each	<u>5,199.29</u>	<u>10,398.58</u>
74	42IN MJ TEE	2	Each	<u>3,875.35</u>	<u>7,750.70</u>
75	30IN MJ TEE	2	Each	<u>1,571.33</u>	<u>3,142.66</u>
76	24IN MJ TEE	2	Each	<u>749.56</u>	<u>1,499.12</u>
77	20IN MJ TEE	2	Each	<u>505.13</u>	<u>1,010.26</u>
78	18IN MJ TEE	2	Each	<u>547.74</u>	<u>1,095.48</u>
79	16IN MJ TEE	2	Each	<u>378.77</u>	<u>757.54</u>
80	14IN MJ TEE	2	Each	<u>275.50</u>	<u>551.00</u>

NOTE: ALL BIDS RECEIVED ARE SUBJECT TO THE TERMS AND CONDITIONS

ALL BIDS MUST BE SIGNED – The undersigned offers the above quoted prices under the conditions contained herein.

The City is Exempt from all Federal and State Tax.  
Bids will be received at the above mentioned address.

COMPANY: PIPELINE SUPPLY CO.

TERMS OF PAYMENT: NET 30

SIGNATURE: [Signature]

TELEPHONE NUMBER: 703 698 8996

NAME AND TITLE: MICHAEL WARREN V.P.

# BID SOLICITATION



City of Chattanooga  
101 East 11th Street, Suite G13  
Chattanooga, TN 37402

**BID OPENING DATE AND TIME:**  
19-APR-18 at 2:00 PM

**BID NUMBER:** 305063

**BUYER:**  
**PHONE #:** (423) 643-7230  
**DELIVERY REQUIRED:**

**SEALED BIDS**

Mail or submit two (2) signed copies of bid form to this office in the enclosed envelope. Retain one copy for your file.

**V  
E  
N  
D  
O  
R**

RFQ

**M  
A  
I  
L  
T  
O**

City of Chattanooga  
101 East 11th Street, Suite G13  
Chattanooga, TN 37402

Item	Class-Item	Quantity	Unit	Unit Price	Total
81	12IN MJ TEE	2	Each	<u>165.71</u>	<u>331.42</u>
82	10IN MJ TEE	2	Each	<u>118.66</u>	<u>237.32</u>
83	8IN MJ TEE	2	Each	<u>83.15</u>	<u>166.30</u>
84	6IN MJ TEE	2	Each	<u>55.34</u>	<u>110.68</u>
85	4IN MJ TEE	2	Each	<u>30.77</u>	<u>61.54</u>
86	54IN MJ PLUG SOLID	2	Each	<u>2485.71</u>	<u>4971.42</u>
87	48IN MJ PLUG SOLID	2	Each	<u>1780.24</u>	<u>3560.48</u>
88	42IN MJ PLUG SOLID	2	Each	<u>1,335.48</u>	<u>2,670.96</u>
89	30IN MJ PLUG SOLID	2	Each	<u>623.20</u>	<u>1246.40</u>
90	24IN MJ PLUG SOLID	2	Each	<u>313.96</u>	<u>627.92</u>

**NOTE: ALL BIDS RECEIVED ARE SUBJECT TO THE TERMS AND CONDITIONS**

ALL BIDS MUST BE SIGNED - The undersigned offers the above quoted prices under the conditions contained herein.

The City is Exempt from all Federal and State Tax.  
Bids will be received at the above mentioned address.

TERMS OF PAYMENT: NET 30

TELEPHONE NUMBER: 423 698 8886

COMPANY: PIPELINE SUPPLY CO.

SIGNATURE: [Signature]

NAME AND TITLE: Michel D'Arcy V.P.

# BID SOLICITATION



City of Chattanooga  
101 East 11th Street, Suite G13  
Chattanooga, TN 37402

**BID OPENING DATE AND TIME:**  
19-APR-18 at 2:00 PM

**BID NUMBER: 305063**

SEALED BIDS

Mail or submit two (2) signed copies of bid form to this office in the enclosed envelope. Retain one copy for your file.

**BUYER:**  
**PHONE #:** (423) 643-7230  
**DELIVERY REQUIRED:**

V  
E  
N  
D  
O  
R

RFQ

M  
A  
I  
L  
T  
O

City of Chattanooga  
101 East 11th Street, Suite G13  
Chattanooga, TN 37402

Item	Class-Item	Quantity	Unit	Unit Price	Total
91	20IN MJ PLUG SOLID	2	Each	<u>226.38</u>	<u>452.76</u>
92	18IN MJ PLUG SOLID	2	Each	<u>172.22</u>	<u>344.44</u>
93	16IN MJ PLUG SOLID	2	Each	<u>138.78</u>	<u>277.56</u>
94	14IN MJ PLUG SOLID	2	Each	<u>108.60</u>	<u>217.20</u>
95	12IN MJ PLUG SOLID	2	Each	<u>52.38</u>	<u>104.76</u>
96	10IN MJ PLUG SOLID	2	Each	<u>53.26</u>	<u>106.52</u>
97	8IN MJ PLUG SOLID	2	Each	<u>30.47</u>	<u>60.94</u>
98	6IN MJ PLUG SOLID	2	Each	<u>20.41</u>	<u>40.82</u>
99	4IN MJ PLUG SOLID	2	Each	<u>10.65</u>	<u>21.30</u>
100	4IN FOSTER ADPT	2	Each	<u>58.00</u>	<u>116.00</u>

NOTE: ALL BIDS RECEIVED ARE SUBJECT TO THE TERMS AND CONDITIONS

ALL BIDS MUST BE SIGNED - The undersigned offers the above quoted prices under the conditions contained herein.

The City is Exempt from all Federal and State Tax.  
Bids will be received at the above mentioned address.

TERMS OF PAYMENT: NET 30

TELEPHONE NUMBER: 423 698 5996

COMPANY: PIPING SUPPLY CO

SIGNATURE: [Signature]

NAME AND TITLE: MICHAEL BRADY VP



# BID SOLICITATION



City of Chattanooga  
101 East 11th Street, Suite G13  
Chattanooga, TN 37402

<b>BID OPENING DATE AND TIME:</b> 19-APR-18 at 2:00 PM  <b>BID NUMBER: 305063</b>
<b>BUYER:</b> <b>PHONE #:</b> (423) 643-7230 <b>DELIVERY REQUIRED:</b>

SEALED BIDS

Mail or submit two (2) signed copies of bid form to this office in the enclosed envelope. Retain one copy for your file.

**V**  
**E**  
**N**  
**D**  
**O**  
**R**

RFQ

**M**  
**A**  
**I**  
**L**  
**T**  
**O**

City of Chattanooga  
101 East 11th Street, Suite G13  
Chattanooga, TN 37402

Item	Class-Item	Quantity	Unit	Unit Price	Total
101	6IN FOSTER ADPT	2	Each	<u>73<sup>00</sup></u>	<u>146<sup>00</sup></u>
102	8IN FOSTER ADPT	2	Each	<u>110<sup>00</sup></u>	<u>220<sup>00</sup></u>
103	10IN FOSTER ADPT	2	Each	<u>165<sup>00</sup></u>	<u>330<sup>00</sup></u>
104	14IN FOSTER ADPT	2	Each	<u>308<sup>00</sup></u>	<u>616<sup>00</sup></u>
105	12IN FOSTER ADPT	2	Each	<u>170<sup>00</sup></u>	<u>340<sup>00</sup></u>
106	16IN FOSTER ADPT	2	Each	<u>333<sup>00</sup></u>	<u>666<sup>00</sup></u>
107	18IN FOSTER ADPT	2	Each	<u>425<sup>00</sup></u>	<u>850<sup>00</sup></u>
108	24IN FOSTER ADPT	2	Each	<u>685<sup>00</sup></u>	<u>1370<sup>00</sup></u>
109	30IN FOSTER ADPT	2	Each	<u>1012<sup>00</sup></u>	<u>2024<sup>00</sup></u>
110	4IN UNI FLG	2	Each	<u>23<sup>00</sup></u>	<u>46<sup>00</sup></u>

NOTE: ALL BIDS RECEIVED ARE SUBJECT TO THE TERMS AND CONDITIONS

ALL BIDS MUST BE SIGNED - The undersigned offers the above quoted prices under the conditions contained herein.

The City is Exempt from all Federal and State Tax.  
Bids will be received at the above mentioned address.

COMPANY: Piscina Service Co

TERMS OF PAYMENT: NET 30

SIGNATURE: [Signature]

TELEPHONE NUMBER: 423 695 8896

NAME AND TITLE: Mitch Wagoner VP

# BID SOLICITATION



City of Chattanooga  
101 East 11th Street, Suite G13  
Chattanooga, TN 37402

**BID OPENING DATE AND TIME:**  
19-APR-18 at 2:00 PM

**BID NUMBER: 305063**

SEALED BIDS

Mail or submit two (2) signed copies of bid form to this office in the enclosed envelope. Retain one copy for your file.

**BUYER:**  
**PHONE #: (423) 643-7230**  
**DELIVERY REQUIRED:**

V  
E  
N  
D  
O  
R

RFQ

M  
A  
I  
L  
T  
O

City of Chattanooga  
101 East 11th Street, Suite G13  
Chattanooga, TN 37402

Item	Class-Item	Quantity	Unit	Unit Price	Total
111	6IN UNI FLG	2	Each	<u>25<sup>00</sup></u>	<u>50<sup>00</sup></u>
112	8IN UNI FLG	2	Each	<u>34<sup>50</sup></u>	<u>68<sup>50</sup></u>
113	10IN UNI FLG	2	Each	<u>63<sup>50</sup></u>	<u>126<sup>50</sup></u>
114	14IN UNI FLG	2	Each	<u>200<sup>00</sup></u>	<u>400<sup>00</sup></u>
115	12IN UNI FLG	2	Each	<u>74<sup>50</sup></u>	<u>148<sup>50</sup></u>

NOTE: ALL BIDS RECEIVED ARE SUBJECT TO THE TERMS AND CONDITIONS

ALL BIDS MUST BE SIGNED - The undersigned offers the above quoted prices under the conditions contained herein.

The City is Exempt from all Federal and State Tax.  
Bids will be received at the above mentioned address.

COMPANY: PIPING SUPPLY CO

TERMS OF PAYMENT: NET 30

SIGNATURE: [Signature]

TELEPHONE NUMBER: 423 688 8896

NAME AND TITLE: Mitch Williams US

Chapter No. 817 (HB0261/SB0377). "Iran Divestment Act" enacted.

Vendor Disclosure and Acknowledgement

By submission of this bid, each bidder and each person signing on behalf of any bidder certifies, and in the case of a joint bid each party thereto certifies as to its own organization, under penalty of perjury, that to the best of its knowledge and belief that each bidder is not on the list created pursuant to § 12-12-106.

(SIGNED) 

(PRINTED NAME) Mitch Warron

(BUSINESS NAME) Piping Supply Co.

(DATE) 4/14/18

For further information, please see website:

[https://www.tn.gov/assets/entitles/generalservices/cpo/attachments/List\\_of\\_persons\\_pursuant\\_to\\_Tenn.\\_Code\\_Ann.\\_12-12-106,\\_Iran\\_Divestment\\_Act-July.pdf](https://www.tn.gov/assets/entitles/generalservices/cpo/attachments/List_of_persons_pursuant_to_Tenn._Code_Ann._12-12-106,_Iran_Divestment_Act-July.pdf)

No Contact/No Advocacy

Notice Receipt

City of Chattanooga

Purchasing Division

For Submission with Sealed Bid Solicitation Responses:

PIPING SUPPLY CO (Vendor Agent name), states that:

(1) He/She is the owner, partner, officer, representative, or agent of \_\_\_\_\_

PIPING SUPPLY CO. (Business name), the Submitter of the

attached sealed solicitation response to Solicitation # 305063, and said

Business has taken notice, and will abide by the following No Contact and No Advocacy clauses:

**NO CONTACT POLICY:** After the posting of this solicitation, a potential submitter is prohibited from directly or indirectly contacting any City of Chattanooga representative concerning the subject matter of this solicitation, unless such contact is made with the Purchasing Division.

**NO ADVOCATING POLICY:** To ensure the integrity of the review and evaluation process, companies and/or individuals submitting sealed solicitation responses, as well as those persons and/or companies formally/informally representing such submitters, may not directly or indirectly lobby or advocate to any City of Chattanooga representative.

**Any business entity and/or individual that does not comply with the No Contact and No Advocating policies may be subject to the rejection or disqualification of its solicitation response from consideration.**

Submitter Signature:

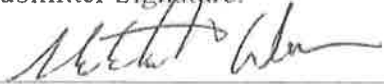

Printed Name:

MITCH WARREN

Title: V.P.

Date: 4/12/18

## Affirmative Action Plan

The City of Chattanooga is an equal opportunity employer and during the performance of this Contract, the Contractor agrees to abide by the equal opportunity goals of the City of Chattanooga as follows:

1. The Contractor will not discriminate against any employee or applicant for employment because of race, color, religion, sex, national origin, or handicap. The Contractor will take affirmative action to ensure that applicants are employed, and that employees are treated during employment without regard to their race, color, religion, sex, national origin, or handicap. Such action shall include, but not be limited to, the following: employment, upgrading, demotion or transfer, recruitment or recruitment advertising, layoff or termination, rates of pay or other forms of compensation, and selection for training including apprenticeship. The Contractor agrees to post in conspicuous places, available to employees and applicants for employment, notices setting forth the provisions of this nondiscrimination clause.
2. The Contractor will, in all solicitations or advertisements for employees placed by or on behalf of the Contractor, state that all qualified applicants will receive consideration for employment without regard to race, color, religion, sex, national origin, or handicap.
3. The Contractor will send to each labor union or representative of workers with which he/she has a collective bargaining agreement or other contract or understanding, a notice advising said labor union or workers' representatives of the Contractor's commitments under this section, and shall post copies of the notice in conspicuous places available to employees and applicants for employment.
4. During the term of all construction contracts or subcontracts in excess of \$10,000 to be performed for the City of Chattanooga, the following non-discriminatory hiring practices shall be employed to provide employment opportunities for minorities and women:
  - a. All help wanted ads placed in newspapers or other publications shall contain the phrase "Equal Employment Opportunity Employer".
  - b. Seek and maintain contracts with minority groups and human relations organizations as available.
  - c. Encourage present employees to refer qualified minority group and female applicants for employment opportunities.
  - d. Use only recruitment sources which state in writing that they practice equal opportunity. Advise all recruitment sources that qualified minority group members and women will be sought for consideration for all positions when vacancies occur.

5. Minority statistics are subject to audit by City of Chattanooga staff or other governmental agency.
6. The Contractor agrees to notify the City of Chattanooga of any claim or investigation by State or Federal agencies as to discrimination.



\_\_\_\_\_  
(Signature of Contractor)

Mitch Ward PIPING SUPPLY Co.

\_\_\_\_\_  
(Title and Name of Company)

4/16/18

\_\_\_\_\_  
(Date)



# City of Chattanooga

Mayor Andy Berke

May 30, 2018

Mr. Justin Holland  
Administrator, Public Works Department  
Waste Resources Division  
1250 Market Street, Suite 2100  
Chattanooga, TN 37402

Subject: 168001 / 305067 – Nidec Motors – Waste Resources Division –  
Public Works Department

Dear Mr. Holland:

Council approval is recommended to issue a purchase order for the purchase of two (2) Nidec Motors for Waste Resources Division, Public Works Department.

The invitation to bid was sent to eight (8) vendors as well as formally advertised. Four (4) responses were received as shown below and on the attachment. Copies of the bids are retained on file and available for review in the Purchasing Office upon request.

<u>Bidder</u>	<u>Bid</u>
Rome Electric Motor Works Inc	\$139,960.00
Tekwell Services	\$143,871.00
Applied industrial Technologies	\$144,952.54
Louis Allis	\$204,672.00

I recommend awarding this purchase to Rome Electric Motor Works Inc, 36 Westside Industrial Blvd, Rome, GA 30165 in the amount of \$139,960.00, who offers the best value bid which meets the specifications for the City of Chattanooga.

Respectfully yours,

Bonnie Woodward  
Director of Purchasing

BW/mlm

Attachments

Bid Tabulation -

Bid# 305067 Nidec Motor(s)

Item #	Item	Quantity	Applied Industrial Technologies Unit Price	Total Price	Tekwell Services Unit Price	Total Price	Rome Electric Motors Unit Price	Total Price	Louis Allis Total Unit Price	Total Price
2	Nidec 350 hI 460V Motor (vertical) form wound, inverter duty to fit existing pump base	2	\$ 72,476.27	\$ 144,952.54	\$ 71,935.50	\$ 143,871.00	\$ 69,980.00	\$ 139,960.00	\$ 102,336.00	\$ 204,672.00



**Applied Industrial Technologies**  
4136 Jersey Pike, Suite A  
Chattanooga, TN 37421

**United Refrigeration Inc**  
1600 East 20th Street  
Chattanooga, TN 37404

**Rome Electric Motor Works Inc**  
36 Westside Industrial Blvd  
Rome, GA 30165

**Chattanooga Industrial Motors**  
P.O. Box 264  
Wildwood, GA 30757

**Chattanooga Armature Works**  
1209 E. 23rd Street  
Chattanooga, TN 37408

**Creswell Richardson**  
900 Appling street  
Chattanooga, TN 37421

**Motion Industries**  
3740 Powers Court, Suite 400  
Chattanooga, TN 37416

**Tekwell Services**  
1301 Galway Street NE  
Knoxville, TN 37917

# BID SOLICITATION



**City of Chattanooga**  
 101 East 11th Street, Suite G13  
 Chattanooga, TN 37402

**BID OPENING DATE AND TIME:**  
 24-APR-18 at 2:00 PM

**BID NUMBER:** 305067

**BUYER:**  
**PHONE #:** (423) 643-7230  
**DELIVERY REQUIRED:**

SEALED BIDS

Mail or submit two (2) signed copies of bid form to this office in the enclosed envelope. Retain one copy for your file.

V  
E  
N  
D  
O  
R

RFQ

M  
A  
I  
L  
T  
O

City of Chattanooga  
 101 East 11th Street, Suite G13  
 Chattanooga, TN 37402

Item	Class-Item	Quantity	Unit	Unit Price	Total
Requisition No.: 168001 Ordering Dept.: Waste Resources Buyer: Geoffrey Hipp 423-643-7233 ***** DESCRIPTION: Nidec Motor per specifications ***** ATTACHMENTS: - Specifications - Iran Divestment Act - Affirmative Action Plan - Standard Terms and Conditions: ( <a href="http://www.chattanooga.gov/purchasing/standard-terms-and-conditions">http://www.chattanooga.gov/purchasing/standard-terms-and-conditions</a> ) ***** *** BIDS MUST BE RECEIVED NO LATER THAN *** ***** 2:00 PM ON APRIL 24, 2018 ***** ***** PLEASE SUBMIT BIDS IN DUPLICATE INDICATING BID NUMBER (305067) ON OUTSIDE PACKAGING ALL ITEMS MUST BE QUOTED F.O.B. DESTINATION, FREIGHT ALLOWED. ***** NOTE: All bids received are subject to the terms and conditions contained herein and as listed in the above referenced website. The undersigned Bidder acknowledges having received, reviewed, and agrees to be bound to these terms and conditions, unless specific written exceptions are otherwise stated.  The City of Chattanooga reserves the right to reject any and/or all bids, waive any informalities in the bids received, and to accept any bid which in its opinion may be for the best interest of the city.  The City of Chattanooga will be non-discriminatory in the purchase of all goods and services on the basis of race, color, or national origin. ***** PLEASE PROVIDE US WITH THE FOLLOWING INFORMATION: Company Name <u>Rome Electric Motors</u> Address <u>36 Westside Ind. Blvd.</u> Phone/Toll-Free No. <u>800-241-2108</u> Fax No. <u>706-552-2071</u> E-Mail Address <u>bill@romeelectric.com</u> Contact Person's Name <u>Bill Bowling</u> Estimated Delivery <u>8-10 weeks</u> Minority-Owned Business <input type="checkbox"/> Small Business <input type="checkbox"/> Veteran <input type="checkbox"/> Minority Woman Owned Business <input type="checkbox"/> Disabled Veteran <input type="checkbox"/> Women-Owned Business <input type="checkbox"/>					
				<i>1 each \$71,390<sup>00</sup></i> <i>For 2 each \$69,980<sup>00</sup> each</i>	

NOTE: ALL BIDS RECEIVED ARE SUBJECT TO THE TERMS AND CONDITIONS

ALL BIDS MUST BE SIGNED – The undersigned offers the above quoted prices under the conditions contained herein.

The City is Exempt from all Federal and State Tax.  
 Bids will be received at the above mentioned address.

COMPANY: Rome Electric Motors

TERMS OF PAYMENT: net 30

SIGNATURE: Bill Bowling

TELEPHONE NUMBER: 706-552-4483

NAME AND TITLE: Bill Bowling - Pres.

# BID SOLICITATION



City of Chattanooga  
101 East 11th Street, Suite G13  
Chattanooga, TN 37402

**BID OPENING DATE AND TIME:**  
24-APR-18 at 2:00 PM

**BID NUMBER: 305067**

SEALED BIDS

Mail or submit two (2) signed copies of bid form to this office in the enclosed envelope. Retain one copy for your file.

**BUYER:**  
**PHONE #:** (423) 643-7230  
**DELIVERY REQUIRED:**

V  
E  
N  
D  
O  
R

RFQ

M  
A  
I  
L  
T  
O

City of Chattanooga  
101 East 11th Street, Suite G13  
Chattanooga, TN 37402

Item	Class-Item	Quantity	Unit	Unit Price	Total
1	Nidec 350 hp 460V Motor (vertical) form wound, inverter duty to fit existing pump base, per attached specs	1	Each	74,300.00	-
		0		65,980.00	

NOTE: ALL BIDS RECEIVED ARE SUBJECT TO THE TERMS AND CONDITIONS

ALL BIDS MUST BE SIGNED – The undersigned offers the above quoted prices under the conditions contained herein.

The City is Exempt from all Federal and State Tax.  
Bids will be received at the above mentioned address.

TERMS OF PAYMENT: net 30

TELEPHONE NUMBER: 706-251-4483

COMPANY: Rome Electric Motors

SIGNATURE: [Signature]

NAME AND TITLE: Bill Bowling - Pres.

**ADDENDUM NO: 1**

**REQ NO: 168001**

**FINAL SUBMITTAL: April 18, 2018 2:00 PM EST**

**FINAL QUESTIONS: N/A**

**Department: Waste Resource Division, Public Works**

**Changes to Bid No. 305067:**

The Waste Resource Division would like to also bid on a quantity of two (2) Nidec Motors along with the one (1) they set out to bid on.

71,390<sup>00</sup> Price for one (1) Nidec Motor as listed on the ITB

69,980<sup>00</sup> Price for two (2) Nidec Motors

The Waste Water Division will determine if one (1) or two (2) motors will be Purchased..

Since this is a critical piece to Waste Resource Division, the Bid Opening will be changed to April 18, 2018 at 2:00 PM EST instead of the original April 24<sup>th</sup> date.

Req No: 168001 Nidec Motor

PLEASE SIGN ONE (1) COPY OF ADDENDUM AND RETURN TO THE PURCHASING DEPARTMENT. RETAIN THE OTHER COPY FOR YOUR FILES.

Name:

*Bill Bowling*

Company:

*Rome Electric Motor Works*

CITY OF CHATTANOOGA  
PURCHASING DEPARTMENT  
Mark McKeel  
City Hall Suite G13  
CHATTANOOGA, TN 37402  
TELE: (423) 643-7236  
FAX: (423) 643-7244



# Quotation

Dan Maher  
**NIDEC MOTOR CORPORATION**  
 8050 West Florissant Avenue  
 St. Louis, MO 63136  
 T (770) 517-9248  
 M (404) 432-9521  
 E [dan.maher@nidec-motor.com](mailto:dan.maher@nidec-motor.com)

Date: April 4, 2018  
 Customer: Rome Electric Motor  
 Attention: Bill Bowling  
 Reference: CITY OF CHATTANOOGA

Quote Number: 17MHE0912A REV B  
 Issued by: Mary Ann Espineda

CURRENT			PHASE			CYCLES		VOLTS	
AC			3			60		460	

ITEM	QTY	HP	FRAME	SPEED	WEIGHT	TYPE	NMC Reference	NET EACH
A	1	350	5813PZ	514	10200 lbs.	RVEI4	1282340	

**DESCRIPTION:**

- Vertical Solid Shaft - High Thrust
- Weather Protected Type – I Enclosure
- Form Wound
- 1.15 Service Factor on Sine Wave Power
- 1.00 Service Factor on VFD Power
- Class F Insulation
- Insulife - 5000 Insulation Treatment
- 3,300 Feet Altitude (Max)
- +40 °C Ambient Temperature
- Premium Efficient
- Base Diameter: 30.5 Inches
- Pricebook Thrust Value: 18500 lbs.
- Customer Down Thrust: 11800 lbs.
- Inverter Duty NEMA MG1 Part 31
- Variable Torque ~ Speed Range 10:1
- "B" Rise @ 1.0 SF (By Resistance Method on Sine Wave Power)
- Vertical Centrifugal Pump Application
- Direct-On-Line Start/VFD
- Continuous Duty
- Shaft Ground Ring
- Insulated Bearing - Upper Bracket
- Special Balance
- Bearing RTD-100 Ohm ~ Both Bearing
- Winding RTD's-100 Ohm ~ Qty 3/phase
- Size 4.5 Conduit Box-Fabricated Steel Copper Bus Bar Standoff Insulators
- Robertshaw 366A8 Vibration Switch Qty-2 Upper End Bracket 90 Degrees Apart
- Qty-1 Accessory Outlet Box One Box with Terminal Board

**Special Shaft Dimensions: 5813PZ**

- U=3.875"
- AH/V=7.000"
- KEYWAY=1.000"
- ES=4.500"

**Quote Comments:**

1. Quoted motor is not a duplicate or direct replacement of other manufacturer's motor. We are quoting Nidec standard frame size matching the base diameter and special shaft dimensions as listed above. Please verify if the quoted motor will fit the existing application. See attached Dimension Print for complete dimensional details.
2. Quoting VFD Duty motor as per data sheet.
3. Exception to quantity 8 RTD, motor is quoted with quantity 2 per phase winding RTD.
4. Quoted total of 2 bearing RTD 1 each for lower and upper bracket, if different is required please ask for a re-quote.
5. Size 4.5 Conduit box is not rotatable.
6. Providing quantity 2 vibration switch on upper bearing as per drawing, if different is required please ask for a re-quote.
7. All auxiliary components, monitors, relays, couplings, anchor bolts, VFD's, cables, sole plates, bed plates and other external controls are provided by others.



† All non-Nidec Motor Corporation marks shown within this document are properties of their respective owners.  
 \* Nidec trademarks followed by the ® symbol are registered with the U.S. Patent and Trademark Office.

## EQ NIDEC MOTOR 350HP

- Vertical Shaft Motor
- High Thrust-WPI Enclosure
- B: Form Wound
- +40 Deg C Ambient Temperature
- Premium Efficiency
- 30.5" Diameter Base Inverter Duty Windings
- "B" rise @ 1.0 S.F. (Resistance On Sine Wave Power)
- Continuous Duty
- Shaft Ground Ring
- Insulated Bearing – Upper Bracket
- Includes 8 ea RTD 100 ohm in winding
- 2 each Bearing RTD's (Upper & Lower)
- 2 each Mounting for Robert Shaw "Vibration Switch"
- Busbar Enclosure to Connect Motor to existing leads in Cable Tray
- Placement according to EQ Nidec 350 HP Motor Drawing
- 3 7/8" Shaft

*Don D...*

*12/6/17*

# EQ 350 HP Nidec Motor Placement

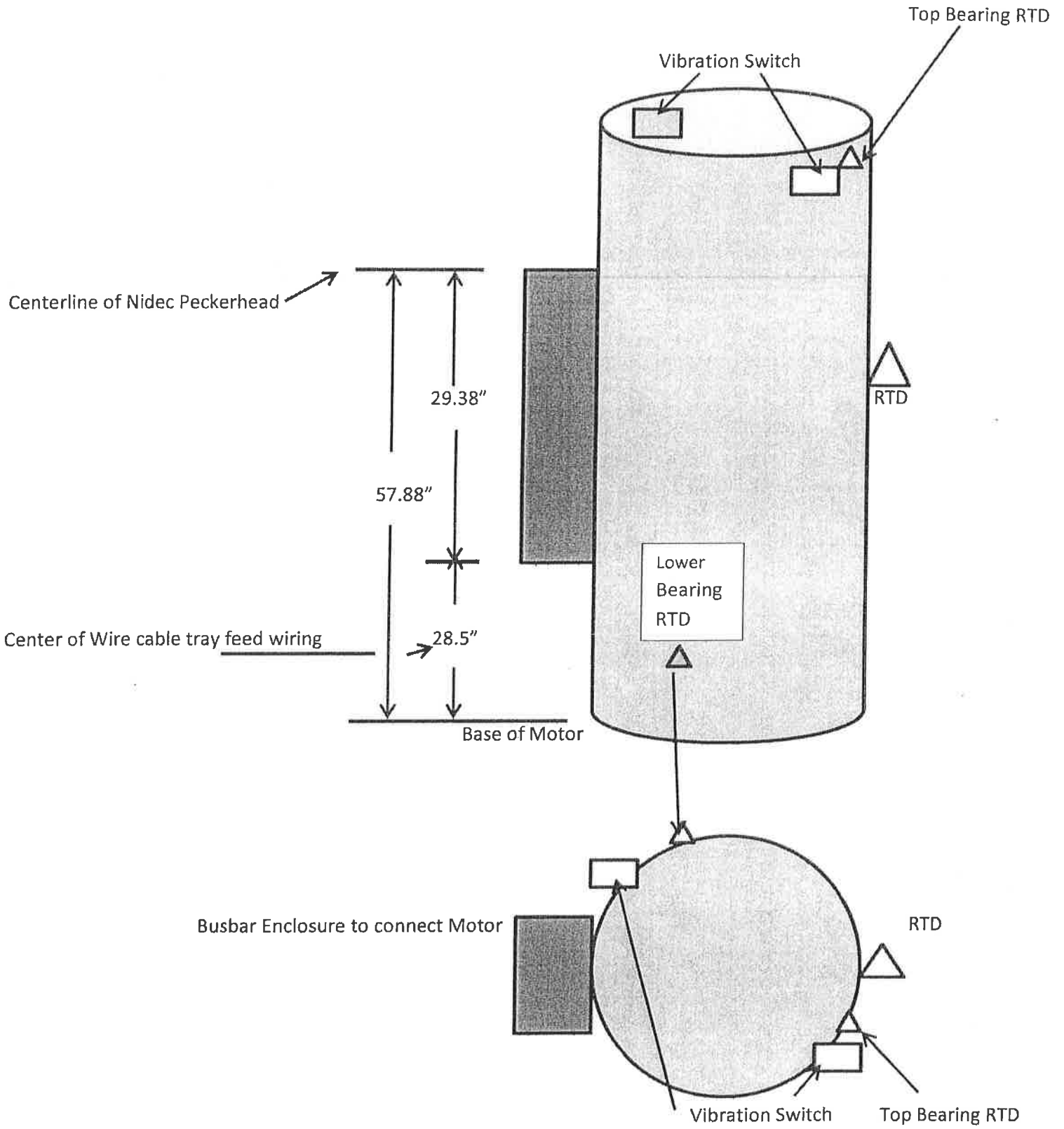



EFFECTIVE:  
30-MAR-11

SUPERSEDES:  
26-AUG-10

# DIMENSION PRINT

WEATHER PROTECTED TYPE I  
FRAME: 5813 VP, VPA  
TYPE: RV4

PRINT:  
09-2792

SHEET:  
1 OF 1

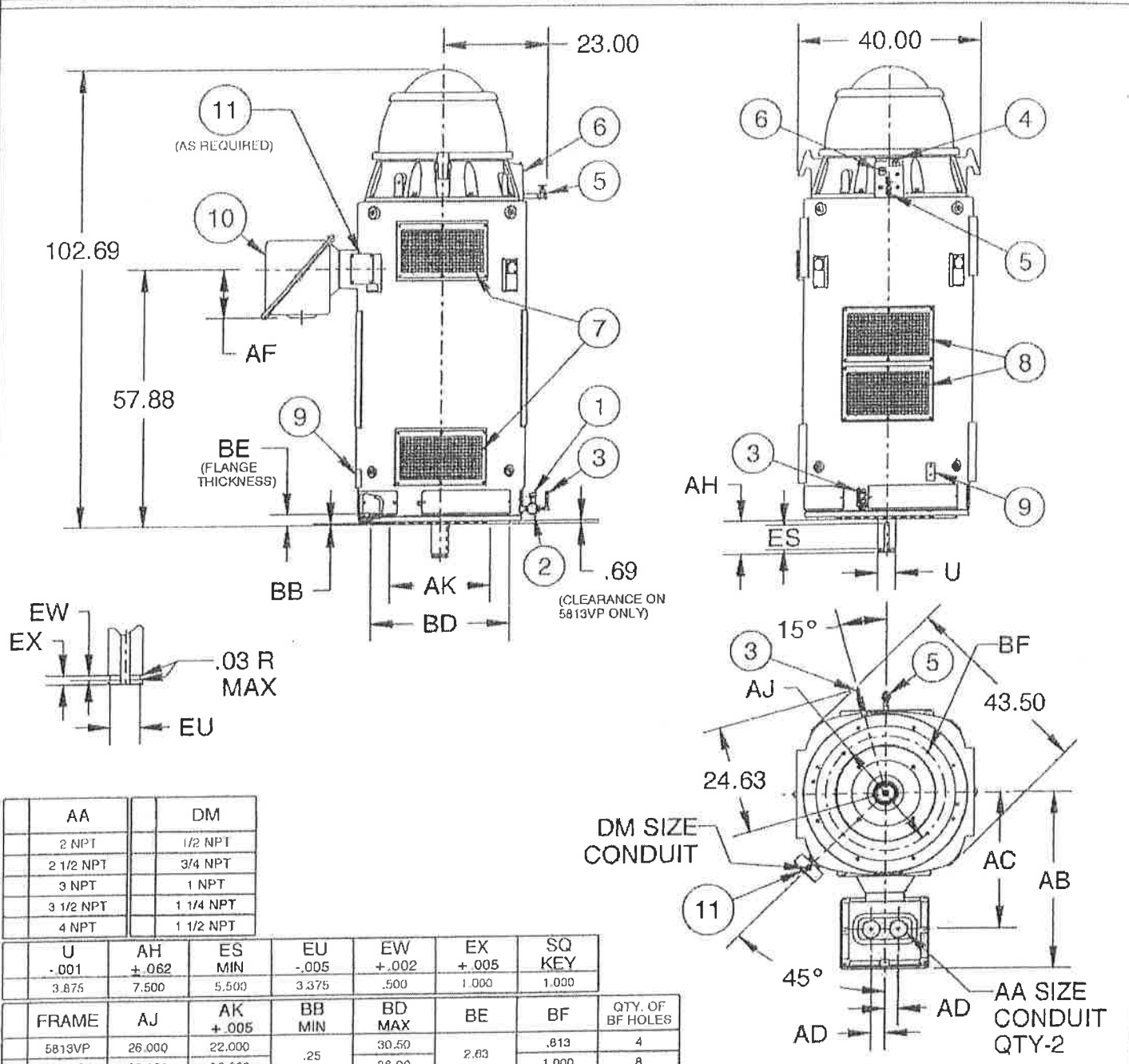

AA	DM
2 NPT	1/2 NPT
2 1/2 NPT	3/4 NPT
3 NPT	1 NPT
3 1/2 NPT	1 1/4 NPT
4 NPT	1 1/2 NPT

U	AH	ES	EU	EW	EX	SQ
-.001	±.062	MIN	-.005	+.002	+.005	KEY
3.875	7.500	5.500	3.375	.500	1.000	1.000

FRAME	AJ	AK	BB	BD	BE	BF	QTY. OF BF HOLES
5813VP	26.000	22.000	MIN	MAX			
5813VPA	32.000	26.000	.25	38.00	2.63	.813	4
						1.000	8

C/BOX VOLUME (CU. IN.)	AB	AC	AD	AF
3400	38.37	30.75	3.00	10.94

FEATURE LISTING			
1	LOWER SUMP OIL FILL	6	UPPER SUMP SIGHT WINDOW
2	LOWER SUMP OIL DRAIN	7	AIR INTAKE 160° APART
3	LOWER SUMP SIGHT WINDOW	8	AIR EXHAUST 160° APART
4	UPPER SUMP OIL FILL	9	GRD PADS, DIAG OPP, 50-13
5	UPPER SUMP OIL DRAIN	10	MAIN CONDUIT BOX
		11	ACCESSORY CONDUIT BOX

ALL DIMENSIONS ARE IN INCHES

TOLERANCES	
FACE RUNOUT	007 F 1 R
PERMISSIBLE ECCENTRICITY OF MOUNTING RABBIT	007 F 1 R
PERMISSIBLE SHAFT RUNOUT	003 F 1 R
MAXIMUM SHAFT END PLAY	010
NON MACHINED DIMENSIONS MAY VARY BY ± .26	

09-2792/A

**Nidec Motor Corporation**  
St. Louis, Missouri

INFORMATION DISCLOSED ON THIS DOCUMENT IS CONSIDERED PROPRIETARY AND SHALL NOT BE REPRODUCED OR DISCLOSED WITHOUT WRITTEN CONSENT OF NIDEC MOTOR CORPORATION



ISSUED BY  
N. PAGERE  
APPROVED BY  
R. SCHMIDT

IHP\_DP\_NMICA (MAR-2011) PROENGINEER

## APPLICATION MANUAL FOR ABOVE NEMA MOTORS

### MOTORS & DRIVES DIVISION

Supersedes  
M3603, Pg. 301  
9/86 Issue

Type GV, RGV — NEMA Type P Flange — Solid Shaft — High Thrust — Weather Protected Type I  
Anti-Friction Bearing  
Frames 580 - 30

#### STANDARD DIMENSIONS — IN INCHES

Frame	AG	BV	Q	P	Approx. Ship. Wt. Lbs.
588	61.2	35.5	33.2	33.4	5500
589	65.2	39.5			5800
30JJ/KK	60.1	27.5	39.0	39.6	5300
3020	64.6	29.8			6200
3023	67.6	31.2			6800

#### STANDARD TERMINAL BOX SELECTION

##### TERMINAL BOX SIZES OUTSIDE DIMENSIONS

Frame	Box. Ident.	AA	AB	AC	AF	XD	XL	XW
580	B	3.0	26.1	21.3	10.0	9.5	14.0	9.0
	C	4.0	28.0	23.0	12.0	10.2	15.0	10.0
	D	5.0	29.9	24.3	16.0	12.1	20.5	12.0
	F	5.0	28.6	21.6	16.0	11.5	21.5	14.2
	G	5.0	29.9	22.3	16.0	12.8	25.2	18.2
30	B	3.0	25.5	24.5	10.0	9.5	14.0	9.0
	C	4.0	31.2	26.2	12.0	10.2	15.0	10.0
	D	5.0	33.0	27.4	16.0	12.1	20.5	12.0
	F	5.0	31.8	24.8	16.0	11.5	21.5	14.2
	G	5.0	33.1	25.5	16.0	12.8	25.2	18.2

#### TERMINAL BOX ASSIGNMENT BOX IDENTIFICATION

Horsepower	460V or 575V	2300V	4000V	6600V
Up to 300	B	B	D	NA
301 to 500	D	C	D	G
501 to 600	F	C	D	G
601 to 700	F	D	D	G
701 to 1000	G	D	D	G
1001 to 1750	—	F	D	G

#### STANDARD BASE

Frame	BD	AK	AJ	BF	BD	AK	AJ	BF
580	30.5	22.0	26.00	.812	24.5	13.500	14.75	.812
30	30.5	22.0	26.00	.812	24.5	13.500	14.75	.812

#### ALTERNATE BASE

#### INDICATOR READINGS — IN INCHES

Frame	Max. Face Run Out	Permissible Eccentricity of Mtg. Rabbet	Permissible Coupling Bore Run Out
580/30	.007	.007	.003

Conduit box may be rotated in steps of 90°.

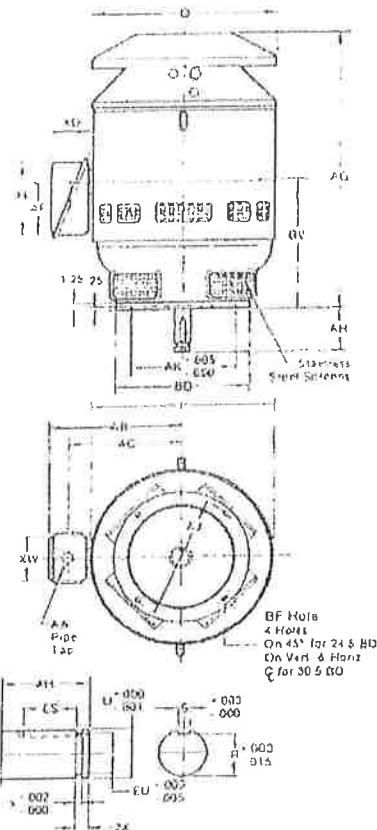

#### SHAFT EXTENSION

Frame	U	EU	AH	X	R	S	ES
580/30	3.675	3.375	7.00	.500	3.309	1.000	4.50

#### Certification:

Customer _____		
P.O. _____	Item _____	
S.O. _____	Item _____	
HP _____	RPM _____	FR _____
PH/Hz/Volts _____		
By _____		Date _____
Rotating Facing Shaft Extension		
CW <input type="checkbox"/>	CCW <input type="checkbox"/>	Either <input type="checkbox"/>

Not for construction, installation or application purposes unless certified.

**No Contact/No Advocacy**

**Notice Receipt**

City of Chattanooga  
Purchasing Division

**For Submission with Sealed Bid Solicitation Responses:**

Bill Bowling  
Rome Electric Motor Works (Vendor Agent name), states that:

(1) He/She is the owner, partner, officer, representative, or agent of Rome Electric

Motor Works (Business name), the Submitter of the

attached sealed solicitation response to Solicitation # 305067, and said

Business has taken notice, and will abide by the following No Contact and No Advocacy clauses:

**NO CONTACT POLICY:** After the posting of this solicitation, a potential submitter is prohibited from directly or indirectly contacting any City of Chattanooga representative concerning the subject matter of this solicitation, unless such contact is made with the Purchasing Division.

**NO ADVOCATING POLICY:** To ensure the integrity of the review and evaluation process, companies and/or individuals submitting sealed solicitation responses, as well as those persons and/or companies formally/informally representing such submitters, may not directly or indirectly lobby or advocate to any City of Chattanooga representative.

**Any business entity and/or individual that does not comply with the No Contact and No Advocating policies may be subject to the rejection or disqualification of its solicitation response from consideration.**

Submitter Signature:

Bill Bowling

Printed Name:

Bill Bowling

Title: Pres.

Date: 4-14-18

Chapter No. 817 (HB0261/SB0377). "Iran Divestment Act" enacted.  
Vendor Disclosure and Acknowledgement

By submission of this bid, each bidder and each person signing on behalf of any bidder certifies, and in the case of a joint bid each party thereto certifies as to its own organization, under penalty of perjury, that to the best of its knowledge and belief that each bidder is not on the list created pursuant to § 12-12-106.

(SIGNED)   
(PRINTED NAME) Bill Bowling  
(BUSINESS NAME) Rome Electric Motor Works  
(DATE) 4-14-18

For further information, please see website:

[https://www.tn.gov/assets/entitles/generalservices/cpo/attachments/List\\_of\\_persons\\_pursuant\\_to\\_Tenn.\\_Code\\_Ann.\\_12-12-106,\\_iran\\_Divestment\\_Act-July.pdf](https://www.tn.gov/assets/entitles/generalservices/cpo/attachments/List_of_persons_pursuant_to_Tenn._Code_Ann._12-12-106,_iran_Divestment_Act-July.pdf)

## Affirmative Action Plan

The City of Chattanooga is an equal opportunity employer and during the performance of this Contract, the Contractor agrees to abide by the equal opportunity goals of the City of Chattanooga as follows:

1. The Contractor will not discriminate against any employee or applicant for employment because of race, color, religion, sex, national origin, or handicap. The Contractor will take affirmative action to ensure that applicants are employed, and that employees are treated during employment without regard to their race, color, religion, sex, national origin, or handicap. Such action shall include, but not be limited to, the following: employment, upgrading, demotion or transfer, recruitment or recruitment advertising, layoff or termination, rates of pay or other forms of compensation, and selection for training including apprenticeship. The Contractor agrees to post in conspicuous places, available to employees and applicants for employment, notices setting forth the provisions of this nondiscrimination clause.
2. The Contractor will, in all solicitations or advertisements for employees placed by or on behalf of the Contractor, state that all qualified applicants will receive consideration for employment without regard to race, color, religion, sex, national origin, or handicap.
3. The Contractor will send to each labor union or representative of workers with which he/she has a collective bargaining agreement or other contract or understanding, a notice advising said labor union or workers' representatives of the Contractor's commitments under this section, and shall post copies of the notice in conspicuous places available to employees and applicants for employment.
4. During the term of all construction contracts or subcontracts in excess of \$10,000 to be performed for the City of Chattanooga, the following non-discriminatory hiring practices shall be employed to provide employment opportunities for minorities and women:
  - a. All help wanted ads placed in newspapers or other publications shall contain the phrase "Equal Employment Opportunity Employer".
  - b. Seek and maintain contracts with minority groups and human relations organizations as available.
  - c. Encourage present employees to refer qualified minority group and female applicants for employment opportunities.
  - d. Use only recruitment sources which state in writing that they practice equal opportunity. Advise all recruitment sources that qualified minority group members and women will be sought for consideration for all positions when vacancies occur.

5. Minority statistics are subject to audit by City of Chattanooga staff or other governmental agency.
6. The Contractor agrees to notify the City of Chattanooga of any claim or investigation by State or Federal agencies as to discrimination.

*Bill R. J.*

---

(Signature of Contractor)

*Pres - Rime Electric Motor Works*

---

(Title and Name of Company)

*4-14-18*

---

(Date)



# City of Chattanooga

Mayor Andy Berke

May 30, 2018

Mr. Justin Holland  
Administrator, Public Works Department  
Fleet Management Division  
1250 Market Street, Suite 2100  
Chattanooga, TN 37402

Subject: 168786 / 305105 – Isuzu Cab & Chassis – Fleet Management Division – Public Works Department

Dear Mr. Holland:

Council approval is recommended for the purchase of one (1) Isuzu Cab & Chassis, Fleet Management Division, Public Works Department.

The invitation to bid was sent to twelve (12) vendors as well as formally advertised. Bids were received from three (3) vendors shown below. Bids are retained on file in the Purchasing Office for your review upon request.

<u>Vendors</u>	<u>Bid</u>
MHC Isuzu	\$49,900.00 (Incomplete Bid)
Lee-Smith, Inc	\$74,003.94
CMI Equipment Sales, Inc	\$81,266.00

I recommend awarding this purchase to Lee-Smith, Inc, 2600 8th Avenue, Chattanooga, TN 37407 in the amount of \$74,003.94. MHC Isuzu did not bid the 5-year Aftertreatment Warranty, took exceptions to the removal and re-installation on a 10 foot Box Body and re-install on the new chassis, Tommy Lift not included, back-up camera and color monitor not included, and radio requirements not included. This made MHC Isuzu's bid incomplete and not able to evaluate properly. Therefore, Fleet Management Division recommends awarding this purchase to Lee-Smith, Inc, who offers the best value bid which meets specifications of the City of Chattanooga.

Respectfully yours,

Bonnie Woodward  
Director of Purchasing

BW/mlm

Attachments

Requisition:		168786		Lee-Smith, Inc		CMI Equipment Sales, Inc		MHC ISUZU		
Bid #:		305105								
Description:		Isuzu Cab & Chassis								
Item #	Item Description	Unit Price	Qty.	Extended Price	Unit Price	Qty.	Extended Price	Unit Price	Qty.	Extended Price
1	Isuzu 2019 Cab & Chassis	\$71,603.94	1	\$ 71,603.94	\$78,866.00	1	\$ 78,866.00	\$49,900.00	1	\$ 49,900.00
1	5-Year Aftertreatment Warranty Plus	\$ 2,400.00	1	\$ 2,400.00	\$ 2,400.00	1	\$ 2,400.00	No Bid	1	
<b>Totals:</b>				\$ 74,003.94			\$ 81,266.00			\$ 49,900.00
** Did not bid the 5-Year Aftertreatment										
** Warranty. Took exceptions to removal & reinstall of a 10 Ft Box Body and Reinstall on the new chassis, Tommy Lift not included,										
** Back-up camera and color monitor, and Radio requirements										



**Lee-Smith, Inc.**  
2600 8<sup>th</sup> Avenue  
Chattanooga, TN 37407

**Ted Russell Isuzu Truck**  
9925 Parkside Drive  
Knoxville, TN 37922

**Neely Coble Isuzu Truck**  
319 Fesslers Lane  
Nashville, TN 37210

**Truckworx Isuzu**  
2220 Finley Blvd  
Birmingham, AL 35234

**Middle Georgia Isuzu Truck**  
6391 Hawkinsville Road  
Macon, GA 31216

**Rush Isuzu Truck**  
2560 Moreland Avenue  
Atlanta, GA 30315

**Rush Isuzu Truck**  
2120 Atlanta Street  
Smyrna, GA 30080

**Gainesville Isuzu Truck**  
2145 Athens Hwy  
Gainesville, GA 30507

**Bellamy-Strickland Isuzu Truck**  
145 Industrial Blvd  
McDonough, GA 30253

**MHC Isuzu Truck**  
1895 Old Haywood Road  
Asheville, NC 28806

**Christopher Isuzu Truck**  
1601 Whitehorse Road  
Greenville, SC 29605

**Triad Isuzu Truck**  
841 Eastern Star Road  
Kingsport, TN 37663

Date: May 1, 2018

Requisition No.: 168786

**PURCHASING DEPARTMENT  
101 EAST 11<sup>TH</sup> STREET  
CITY HALL  
SUITE G13  
CHATTANOOGA, TENNESSEE  
37402**

**Request for Bid (RFB) for the City of Chattanooga, Tennessee**

*Proposals will be received at 101 East 11<sup>th</sup> Street, Suite G13,  
Chattanooga, TN 37402 until 2:00 P.M., EST. on May 16, 2018*

**Requisition / Bid No.: R168786 / 305105  
Ordering Dept.: Fleet Management Division, Public Works  
Buyer & E-mail: Mark McKeel mmckeel@chattanooga.gov**

\*\*\*\*\*

**Items Being Purchased: Isuzu Cab & Chassis**

\*\*\*\*\*

**\*\*\*REQUEST FOR BIDS MUST BE RECEIVED\*\*\***

**2:00 P.M., EST on May 16, 2018**

\*\*\*\*\*

**\*\*\*PRE-BID CONFERENCE WILL BE CONDUCTED\*\*\***

**10:00 A.M., EST on May 9, 2018**

\*\*\*\*\*

The City of Chattanooga reserves the right to reject any and/or all proposals, waive any informality in the proposals received, and to accept any proposal which in its opinion may be for the best interest of the City.

The City of Chattanooga will be non-discriminatory in the purchase of all goods and services on the basis of race, color or national origin.

The City's Standard Terms and Conditions may be found on website:  
<http://www.chattanooga.gov/purchasing/standard-terms-and-conditions>

**Note: ALL BIDS MUST BE SIGNED**

All proposals received are subject to the terms and conditions contained herein and as listed in the above referenced website. The undersigned Offeror acknowledges having received, reviewed, and agrees to be bound to these terms and conditions, unless specific written exceptions are otherwise stated.

**PLEASE PROVIDE THE FOLLOWING INFORMATION:**

Company Name: LEE-SMITH INC  
Mailing Address: 2600 8<sup>TH</sup> AVE  
City & Zip Code: CHATTANOOGA TN 37407  
Phone/Toll Free No.: 423-622-4161  
Fax No.: 423-629-9540  
E-Mail Address: AAshford@lee-smith.com  
Contact Person: ANDY ASHFORD  
Company Title: Sales  
Signature: Cindy Ashford

# BID SOLICITATION



**City of Chattanooga**  
 101 East 11th Street, Suite G13  
 Chattanooga, TN 37402

**BID OPENING DATE AND TIME:**

16-MAY-18 at 2:00 PM

**BID NUMBER: 305105**

**SEALED BIDS**

Mail or submit two (2) signed copies of bid form to this office in the enclosed envelope. Retain one copy for your file.

**BUYER:**

**PHONE #: (423) 643-7230**

**DELIVERY REQUIRED:**

V  
E  
N  
D  
O  
R

RFQ

M  
A  
I  
L  
T  
O

City of Chattanooga  
 101 East 11th Street, Suite G13  
 Chattanooga, TN 37402

Item	Class-Item	Quantity	Unit	Unit Price	Total
Requisition / Bid No.: 168786 / 305105 Ordering Dept.: Fleet Management Division, Public Works Buyer: Mark McKeel Phone No.: 423-643-7236  Items Being Purchased: isuzu Cab & Chassis  ATTACHMENTS: 1. Specifications (8 pages) 2. Affirmative Action Plan (2 pages) 3. Iran Divestment Act Disclosure (1 Page) 4. No Contact / No Advocacy Notice (1 page) City of Chattanooga (COC) Terms and Conditions posted on Website <a href="http://www.chattanooga.gov/purchasing/standard-terms-and-conditions">http://www.chattanooga.gov/purchasing/standard-terms-and-conditions</a> If you can't download call buyer for a copy.  *** BID MUST BE RECEIVED NO LATER THAN *** *** 2:00 PM EST ON MAY 16, 2018 ***  Please submit bids in duplicate indicating bid number (305105) on outside of package. all items must be quoted F.O.B. destination, freight allowed  NOTE: ALL BIDS MUST BE SIGNED All bids received are subject to the terms and conditions contained herein and as listed in the above referenced website. The undersigned Bidder acknowledges having received, reviewed, and agrees to be bound to these terms and conditions, unless specific written exceptions are otherwise stated.  Any manufacturer's names, trade names, brand names, or catalog numbers used in the specifications are for the purpose of describing and establishing general quality levels. Such references are not intended to be restrictive. Bids will be considered for any brand which meets or exceeds the quality of the specifications listed for any item.  The City of Chattanooga reserves the right to reject any and/or all bids, waive any informalities in the bids received, and to accept any bid which in its opinion may be for the best interest of the city.  The City of Chattanooga will be non-discriminatory in the purchase of all goods and services on the basis of race, color, or national origin.  **** NOTE **** PLEASE PROVIDE US WITH THE FOLLOWING INFORMATION: Company Name <u>Lee-Smith Inc</u> Address <u>2600 8th AVE</u> <u>Chattanooga TN 37407</u> Phone/Toll-Free No. <u>423-622-4161</u> Fax No. <u>423-629-9540</u>					

# BID SOLICITATION



City of Chattanooga  
 101 East 11th Street, Suite G13  
 Chattanooga, TN 37402

**BID OPENING DATE AND TIME:**

16-MAY-18 at 2:00 PM

**BID NUMBER:** 305105

**BUYER:**

**PHONE #:** (423) 643-7230

**DELIVERY REQUIRED:**

**SEALED BIDS**

Mail or submit two (2) signed copies of bid form to this office in the enclosed envelope. Retain one copy for your file.

V  
E  
N  
D  
O  
R

RFQ

M  
A  
I  
L  
T  
O

City of Chattanooga  
 101 East 11th Street, Suite G13  
 Chattanooga, TN 37402

Item	Class-Item	Quantity	Unit	Unit Price	Total
eMail Address <u>AAshford@lee-smith.com</u>					
Contact Person's Name <u>Andy Ashford</u>					
Estimated Delivery <u>45-90 DAYS</u>					
Minority-Owned Business _____ Small Business _____ Veteran _____					
Minority Woman-Owned Business _____ Disabled Veteran _____					
Woman-Owned Business _____					
**** ALL ITEMS MUST BE QUOTED F.O.B. DESTINATION ****					

NOTE: ALL BIDS RECEIVED ARE SUBJECT TO THE TERMS AND CONDITIONS

ALL BIDS MUST BE SIGNED - The undersigned offers the above quoted prices under the conditions contained herein.

The City is Exempt from all Federal and State Tax.  
 Bids will be received at the above mentioned address.

TERMS OF PAYMENT:

Net Due 10 Days After Delivery

TELEPHONE NUMBER:

983-622-4161

COMPANY:

Lee-Smith Inc

SIGNATURE

Andy Ashford

NAME AND TITLE:

Andy Ashford Sales

# BID SOLICITATION



City of Chattanooga  
101 East 11th Street, Suite G13  
Chattanooga, TN 37402

<b>BID OPENING DATE AND TIME:</b> 16-MAY-18 at 2:00 PM <b>BID NUMBER:</b> 305105
<b>BUYER:</b> PHONE #: (423) 643-7230 DELIVERY REQUIRED:

**SEALED BIDS**  
Mail or submit two (2) signed copies of bid form to this office in the enclosed envelope. Retain one copy for your file.

V E N D O R	RFQ
----------------------------	-----

M A I L T O	City of Chattanooga 101 East 11th Street, Suite G13 Chattanooga, TN 37402
----------------------------	---

Item	Class-Item	Quantity	Unit	Unit Price	Total
1	Bid-Replacement Truck-Cab & Chassis only (see specs)	1	Dollar	71603 <sup>94</sup>	71603 <sup>94</sup>
	2019 ISUZU NPR-HD				

**NOTE: ALL BIDS RECEIVED ARE SUBJECT TO THE TERMS AND CONDITIONS**

The City is Exempt from all Federal and State Tax.  
Bids will be received at the above mentioned address.

ALL BIDS MUST BE SIGNED - The undersigned offers the above quoted prices under the conditions contained herein.

TERMS OF PAYMENT: Net Due 10 Days After Delivery  
TELEPHONE NUMBER: 423-622-4161

COMPANY: Lee-Smith INC  
SIGNATURE: Andy Ashford  
NAME AND TITLE: ANDY Ashford sales

**ADDENDUM NO: 1**

**REQ NO: 168786**

**FINAL SUBMITTAL: May 23, 2018 2:00 PM EST**

**FINAL QUESTIONS: May 18, 2018 2:00 PM EST**

**Department: Fleet Management**

**Changes to Bid No. 305105:**

**Attached you will find the final version of the Isuzu Cab & Chassis as discussed in the pre-bid on May 9th.**

**The Bid Opening will be extended one week to May 23, 2018 at 2:00 PM.**

**Req No: 1687786 Isuzu Cab & Chassis**

**PLEASE SIGN ONE (1) COPY OF ADDENDUM AND RETURN TO THE PURCHASING DEPARTMENT. RETAIN THE OTHER COPY FOR YOUR FILES.**

**Name:**

Andy Ashford 

**Company:**

LEE-SMITH INC  
2600 8<sup>th</sup> AVE CHATTANOOGA TN

**CITY OF CHATTANOOGA  
PURCHASING DEPARTMENT  
Mark McKeel  
City Hall Suite G13  
CHATTANOOGA, TN 37402  
TELE: (423) 643-7236  
FAX: (423) 643-7244**

# **Chattanooga Fleet Services Fleet Management Specifications Isuzu Cab and Chassis**

## **Introduction**

The attached specifications describe the requirements for a Replacement Cab and chassis truck and accessories to be purchased by the Chattanooga Public Works Department, Fleet Management division. The specifications are intended to be flexible enough for all major manufacturers to comply. The uses of names or part numbers are used for cross referencing to another brand name to be equivalent or greater to the specifications. Height and weight will be posted in cab in driver's field of view. Any and all wear items will be identified and defined in the bid.

## **Bid Requirements**

1. The entire vehicle/apparatus is to conform to D.O.T., FMVSS, NFPA, and OSHA and to the requirements of all other applicable regulatory agencies.
2. Parts not specifically mentioned that are necessary to furnish a complete chassis or body/apparatus must have been produced using the automotive industries best manufacturing practices. This pertains to design, quality of materials and workmanship.
3. Using the attached specifications, bidders must indicate either "yes" or "no" to the right of all line specifications. Exceptions or "no" responses are to be listed and FULLY Explained on a separate page. Failure to complete the spreadsheet or failure to properly document exceptions to the specifications may result in the bid being declared "non-conforming".
4. Loose and miscellaneous equipment is to be provided only as required by D.O.T and specifications, Fire extinguisher, First aid kit and safety triangles shall be included.
5. Each bid is to be accompanied by a set of manufacturer's and as applicable, vendor's specifications. These are to consist of a detailed description of the proposed vehicle/apparatus and equipment. The specifications are to indicate size, type, model and make of all component parts and equipment. A CAD drawing of the proposed vehicle indicating wheelbase, Cab to axle and Cab to end of frame measurements is desired. All weights and horsepower/torque to transmission ratios to axle ratios shall be approved by engineering per vehicle manufacturer to include all detachable components and operations.

All vehicles will be delivered with factory service manuals, wiring diagrams and component locators for cab, chassis & bodies installed on vehicle. CD's or DVD will be accepted.

All warranties will be listed with specific details as to time, including any and all exclusions. No warranties can be Terminated or canceled for any reason during the warranty coverage as stated in bid where specified. No travel or drive time will be paid while under any manufacturer's warranty.

All power train components, assemblies, subassemblies, component parts and so on, will be designed and constructed with due consideration to the nature and distribution of the load to be sustained and to the general character of the service to which the vehicle is designed for and to be subjected to when placed in service. All parts of the vehicle will be strong enough to withstand the general service under full load. The vehicle will be so designed that the various parts are readily accessible for lubrication, inspection, adjustment and repair. Where ever possible, a central lubrication Block shall be provided with zerks and plumbed to withstand air grease gun applications, this includes hoses and connectors so service personnel will be able to perform this at ground level.

All vehicles will be supplied with a line sheet to include as built and current part numbers of any and all components installed on vehicle.

The specified vehicle will be capable of reaching and maintaining a minimum speed of 20 MPH on any grade up to and including 25% or 15 degree grade. The vehicle will be capable of attaining a true speed of 35 MPH in 25 seconds and programmed not to exceed 62 MPH.

All warranty registrations will be completed by bidder and copies provided upon delivery, all warranties will begin on any and all components on the in service date or delivery date if no special training is needed to begin operating vehicle.

Any special software or hardware needed to perform diagnostics on any computer mounted on cab, chassis and body shall be provided by bidder. This includes Transmission, ABS Brake system and Engine.

- A. Warranty YES NO
1. Warranty period shall be for three (3) years on the Cab and Chassis, bodies and ALL of its components with no exceptions.
  2. Warranty shall start on in service date.
  3. All warranty registrations shall be completed by the vendor and copies provided.



4. Factory service manuals, electrical schematics and component locators to be supplied for body, Cab and chassis. ✓
5. Bid an optional Warranty period to be "bumper to bumper" and defined by the bidder, for five (5) years on the body, chassis, engine, transmission and drivetrain, excluding wear items, which must be detailed, with no provision for canceling warranties. ✓
- ~~6.~~ Ten (10) workday repair completion guarantee. The primary vendor will pay the lease cost per day of each day after the tenth day turnaround period has elapsed. Partial days will be prorated based upon an eight (8) hour work day, beginning at 8:00 am. ✓
- ~~7.~~ Instead of the lease cost per day Ten (10) work day repair completion guarantee penalty, the vendor can provide a loaner vehicle of equal to or better quality specifications of the rear load garbage truck that has exceeded the ten day repair limit. ✓
8. Bidder shall include copy of warranty terms and conditions and a list of any exceptions from the warranty. ✓
9. All warranty work for cab, chassis, and body shall be the responsibility of the Primary bidder. ✓

B. Training

1. Minimum of 2-hour professional training for operators. ✓
2. Minimum of 2 day training to be available to on site shop personnel. ✓

### Radio Requirements in Cab

- ✓ 1. 20 amp circuit power and ground shall be provided with an additional 4 amp ignition feed.
- ✓ 1. RG58 Antenna cable with 800 MHz NMO mount and mini UHF connector.

## **New vehicle 16,000 GVWR**

### **Isuzu**

- ✓ **Engine:** 4HK1-TC, diesel engine 317 CID (5.19L), 215 HP at 2550 RPM; 452 ft.-lb. gross torque at 1850 RPM. 4 cylinder, 16 valve, four cycle, overhead cam, turbocharged, inter-cooled, water cooled EGR valve, direct injection, electronically controlled common rail fuel system, engine cruise control function. Oil level check switch and light. Engine Warning system with audible warning for low oil pressure, high coolant temperature, and low coolant level.
- ✓ **Transmission:** IR7 Aisin A465/6-speed automatic transmission
- ✓ **Wheelbase:** 109 inches, includes ladder type channel frame. Full C section straight frame 33.5 inches wide. Yield strength 44,000 psi; section modulus 7.20 in<sup>3</sup> RBM 316,800 lb./ft./in. per rail.
- ✓ **Air Cleaner:** Dry Paper single element. (Donaldson brand) Air cleaner canister standard with air restriction indicator in the drivers multi-information display  
**Alternator:** 140 AMP. with integral regulator.
- ✓ **Battery:** Dual 12-Volt maintenance free group 31 750 CCA batteries with threaded posts
- ✓ **Exhaust:** Single horizontal with DPF/SCR exhaust system

- ✓ **Front Axle:** "1"-beam rated at 6,830 lbs. Includes integral hydraulic power steering. Ratio 18.8-20.9:1.
  
- ✓ **Front Suspension:** 8440 lbs. Capacity semi elliptical tapered leaf spring. Includes shock absorbers and stabilizer bar
  
- ✓ **Front Wheels:** 19.5" x 6", 6-hole disc, painted white
- ✓ **Front Tires:** 225/70R19.5F (12 ply) tubeless Radial, all season
- ✓ **Rear Suspension:** 14,308 lbs. capacity. Semi-elliptical main and auxiliary multi-leaf springs. Includes shock absorbers.
  
- ✓ **Rear Axle:** R040, single-speed, 11,020 lb. capacity with oil lubricated rear wheel bearings.
  
- ✓ **Ratio:** 4.77
- ✓ **Rear Wheels:** 19.5" x 6", 6-hole disc, painted white
- ✓ **Rear Tires:** 225/70R19.5F (12 ply) tubeless Radial, all season tread.
  
- ✓ **Fuel Tank:** 30 gal. rectangular fuel tank. Mounted between frame rail through the rail fuel fill. Fuel water separator with dash mounted warning light.
  
- ✓ **Seat:** Driver seat is reclining high back. Two single occupant fold down seats with tray backs.
  
- ✓ **Brakes:** Butterfly valve type exhaust brake  
IR8 Dual circuit, vacuum assisted hydraulic with EBD

(Electronic Brake Distribution). Disc front and self adjust  
outboard mounted drum rear. Mechanical,  
transmission mounted parking brake. Non-asbestos  
semi metallic linings are standard. 4 channel antilock  
brake system.

✓ Power Windows & Door Locks

✓ Radio: AM / FM / CD Stereo Radio

✓ Floor Mats: Standard Floor Mats

✓ Additional Options:

Fire Extinguisher and Triangle Kit mounted in rear  
organizer on standard cab and under rear seat on  
crew cab

Mirror Bracket for 102" wide body

Seat Covers standard cab

Back up alarm

Chrome Grille

Engine emergency shutdown system HWT, LWL,  
LOP

High visibility seat belt (red color, driver and RH  
passenger seat)

Cold weather package (block heater and heated fuel  
filter)

✓ Accessories: Rear body dome lamp switch

AM/FM/CD radio with Aux input/USB port and

Bluetooth RPO

✓ Paint: White Cab w/ Vlper Red frame rails

✓ Tires: Low Rolling resistance Michelln

✓ This will also include the removal and reinstallation of a 10 foot box body and reInstalling on the new Chassis,

A 500 lb rated Tommy Lift with a fold down Aluminum deck is to be included.

✓ Options:

5 Year warranty ~~Bumper to Bumper~~ 1500 + 900 after Treatment

See Attached for  
5 year Ext. Warranty

\$2400 for Both

## Affirmative Action Plan

The City of Chattanooga is an equal opportunity employer and during the performance of this Contract, the Contractor agrees to abide by the equal opportunity goals of the City of Chattanooga as follows:

1. The Contractor will not discriminate against any employee or applicant for employment because of race, color, religion, sex, national origin, or handicap. The Contractor will take affirmative action to ensure that applicants are employed, and the employees are treated during employment without regard to their race, color, religion, sex, national origin, or handicap. Such action shall include, but not be limited to, the following: employment, upgrading, demotion, or transfer, recruitment or recruitment advertising, layoff or termination, rates of pay, or other forms of compensation, and selection for training, including apprenticeship. The Contractor agrees to post in conspicuous places, available to employees and applicants for employment, notices setting forth the provisions of this nondiscrimination clause.
2. The Contractor will, in all solicitations or advertisements for employees placed by or on behalf of the Contractor, state that all qualified applicants will receive consideration for employment without regard to race, color, religion, sex, national origin, or handicap.
3. The Contractor will send to each labor union or representative of workers with which he/she has a collective bargaining agreement or other contract or understanding, a notice advising the said labor union or workers' representatives of the Contractor's commitments under this section, and shall post copies of the notice in conspicuous places available to employees and applicants for employment.
4. In all construction contracts or subcontracts in excess of \$10,000 to be performed for the City of Chattanooga, any contractor and/or subcontractor is further required to file in duplicate within ten (10) days of being notified that it is the lowest responsible bidder, an affirmative action plan with the EEO Director of the City of Chattanooga. This plan shall state the Contractor's goals for minority and women utilization as a percentage of the work force on this project.
5. This Plan or any attachments thereto shall further provide a list of all employees annotated by job function, race, and sex who are expected to be utilized on this project. This plan or attachment thereto shall further describe the methods by which the Contractor or Subcontractor will utilize to make good faith efforts at providing employment opportunities for minorities and women.

During the term of this contract, the Contractor upon request of the City, will make available for inspection by the City of Chattanooga copies of payroll records, personnel documents and similar records or documents that may be used to verify the Contractor's compliance with these Equal Opportunity provisions.

6. The Contractor will include the portion of the sentence immediately preceding paragraph 1 and the provisions of paragraphs 1 through 6 in every subcontract so that such provisions will be requested of each subcontractor. The Contractor agrees to notify the City of Chattanooga of any subcontractor who refuses or fails to comply with these equal opportunity provisions. Any failure or refusal to comply with these provisions the Contractor and/or Subcontractor shall be a breach of this contract.

  
(Signature of Contractor)

  
(Title and Name of Construction Company)

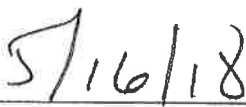
  
(Date)

Chapter No. 817 (HB0261/SB0377). "Iran Divestment Act" enacted.  
Vendor Disclosure and Acknowledgement

By submission of this bid, each bidder and each person signing on behalf of any bidder certifies, and in the case of a joint bid each party thereto certifies as to its own organization, under penalty of perjury, that to the best of its knowledge and belief that each bidder is not on the list created pursuant to § 12-12-106.

(SIGNED)

Andy Ashford

(PRINTED NAME)

ANDY ASHFORD

(BUSINESS NAME)

LEE-SMITH FINE

(DATE)

5/16/18

For further information, please see website:

[https://www.tn.gov/assets/entities/generalservices/cpo/attachments/List\\_of\\_persons\\_pursuant\\_to\\_Tenn.\\_Code\\_Ann.\\_12-12-106,\\_Iran\\_Divestment\\_Act-July.pdf](https://www.tn.gov/assets/entities/generalservices/cpo/attachments/List_of_persons_pursuant_to_Tenn._Code_Ann._12-12-106,_Iran_Divestment_Act-July.pdf)



No Contact/No Advocacy

Notice Receipt

City of Chattanooga  
Purchasing Division

**For Submission with Sealed Bid Solicitation Responses:**

Andy Ashford (Vendor Agent name), states that:

(1) He/She is the owner, partner, officer, representative, or agent of \_\_\_\_\_

Lee-Smith FNC (Business name), the Submitter of the

attached sealed solicitation response to Solicitation # 305105, and said

Business has taken notice, and will abide by the following No Contact and No Advocacy clauses:

**NO CONTACT POLICY:** After the posting of this solicitation, a potential submitter is prohibited from directly or indirectly contacting any City of Chattanooga representative concerning the subject matter of this solicitation, unless such contact is made with the Purchasing Division.

**NO ADVOCATING POLICY:** To ensure the integrity of the review and evaluation process, companies and/or individuals submitting sealed solicitation responses, as well as those persons and/or companies formally/informally representing such submitters, may not directly or indirectly lobby or advocate to any City of Chattanooga representative.

**Any business entity and/or individual that does not comply with the No Contact and No Advocating policies may be subject to the rejection or disqualification of its solicitation response from consideration.**

Submitter Signature:

Andy Ashford

Printed Name:

Andy Ashford

Title: Sales

Date: 5/16/18



## LEE-SMITH ISUZU TRUCK

Ralph Ashford, Jr | 423-648-6310 | aashford@lee-smith.com

# CITY OF CHATTANOOGA BID #305105



Current report content is based on data as of 2018-05-18 04:51:47. Any performance-related calculations are offered solely as guidelines. Actual vehicle performance will depend on your operating conditions. All information, specifications and pricing in this application are based on the latest information available. Isuzu Commercial Truck of America, Inc. reserves the right to discontinue or change, at any time, without prior notice, the pricing, specifications, options, materials, equipment, design and models.



# LEE-SMITH ISUZU TRUCK

Ralph Ashford, Jr | 423-648-6310 | aashford@lee-smith.com

CITY OF CHATTANOOGA BID #305105 (2019 NPR-XD Cab Chassis, NY1 109", 16,000 GVWR. White, In rail fuel tank with power windows, power door locks and air conditioning)

## Weight Distribution

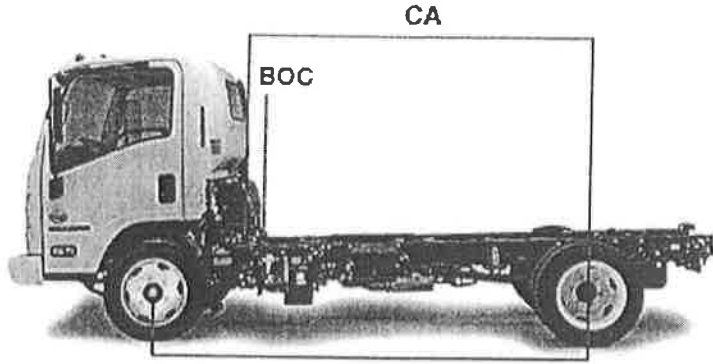

Driver/Passenger Weight	350.0 lbs.
Wheelbase (WB)	109 inches
Cab to Axle(CA)	86.5 inches
Body Length	
Body Weight	
Cab to Body (BOC)	7.7 inches

\*\* You must fill in body length and weight to enable body and payload weight calculations.

<b>Front %</b>	<b>Front Wt.</b>	<b>Rear %</b>	<b>Rear Wt.</b>
67%	4,561.00 lbs.	33%	2,290.00 lbs.
<b>GVWR</b>	<b>GVW</b>	<b>Remaining Payload Weight</b>	
16,000.00 lbs.	6,851.00 lbs.	9,149.00 lbs.	

Weight (lbs.)	Front	Rear	Total
Chassis	4,103.00	2,290.00	6,393.00
Chassis Equipment	108.00	0.00	108.00
Subtotal	4,211.00	2,290.00	6,501.00
Driver/Passengers	350.00	0.00	350.00
Body/Body Equipment	0.00	0.00	0.00
Payload	0.00	0.00	0.00
Total	4,561.00	2,290.00	6,851.00
GAWR/GVWR	6,630.00	11,020.00	16,000.00
GCWR			22,000.00

## Chassis Equipment:

Code	Item	Center of Gravity	Front Axle	Rear Axle	Total
54	White, In rail fuel tank with power windows, power door locks and air conditioning		80.00 lbs.	0.00 lbs.	80.00 lbs.
IF6	Fire Extinguisher and Triangle Kit mounted in rear organizer on standard cab and under rear seat on crew cab		19.00 lbs.	0.00 lbs.	19.00 lbs.
IU2	Mirror Bracket for 102" wide body		1.00 lbs.	0.00 lbs.	1.00 lbs.
V22	Chrome Grille		1.00 lbs.	0.00 lbs.	1.00 lbs.
I0M	Cold weather package (block heater and heated fuel filter)		1.00 lbs.	0.00 lbs.	1.00 lbs.
IV8	Seat Covers standard cab		6.00 lbs.	0.00 lbs.	6.00 lbs.

## Driver/Passengers:

	Center of Gravity	Front Axle	Rear Axle	Total
Driver	front axle	350.00 lbs.	0.00 lbs.	350.0 lbs.

Current report content is based on data as of 2018-05-18 04:51:47. Any performance-related calculations are offered solely as guidelines. Actual vehicle performance will depend on your operating conditions. All information, specifications and pricing in this application are based on the latest information available. Isuzu Commercial Truck of America, Inc. reserves the right to discontinue or change, at any time, without prior notice, the pricing, specifications, options, materials, equipment, design and models.



# LEE-SMITH ISUZU TRUCK

Ralph Ashford, Jr | 423-648-6310 | aashford@lee-smith.com

CITY OF CHATTANOOGA BID #305105 (2019 NPR-XD Cab Chassis, NY1 109", 16,000 GVWR. White, In rail fuel tank with power windows, power door locks and air conditioning)

## Selected Model and Options

	Code	Description	Weight	MSRP
<b>Model</b>				
	NY1	NPR-XD Cab Chassis 109		\$54,156.00
	54	White, In rail fuel tank with power windows, power door locks and air conditioning		\$1,272.00
<b>Tires</b>				
	I5H	LRR (low rolling resistance)	0.0 lbs.	Inc.
<b>Engine</b>				
	I1B	4HK1-TC, diesel engine 317 CID (5.19L), 215 HP at 2550 RPM: 452 ft.-lb. gross torque at 1850 RPM. 4 cylinder, 16 valve, four cycle, overhead cam, turbocharged, inter-cooled, water cooled EGR valve, direct injection, electronically controlled common rail fuel system, engine cruise control function. Oil level check switch and light. Engine Warning system with audible warning for low oil pressure, high coolant temperature, and low coolant level.	0.0 lbs.	Inc.
<b>Transmission</b>				
	IR7	Aisin A465/6-speed automatic transmission, Ratios: 3.742, 2.003, 1.343, 1.00, 0.773, 0.634, Rev 3.539	0.0 lbs.	Inc.
<b>Wheelbase</b>				
	IA8	109 inches, includes ladder type channel frame. Full C section straight frame 33.5 Inches wide. Yield strength 44,000 psi; section modulus 7.20 in <sup>3</sup> RBM 316,800 lb./ft./in. per rail.	0.0 lbs.	Inc.
<b>Air Cleaner</b>				
	KNX	Dry Paper single element. (Donaldson brand) Air cleaner canister standard with air restriction indicator in the driver's Multi-Information Display (MID).	0.0 lbs.	Inc.
<b>Alternator</b>				
	I2C	140 AMP. with integral regulator.	0.0 lbs.	Inc.
<b>Battery</b>				
	IX1	Dual 12-Volt maintenance free group 31 750 CCA batteries with threaded posts	0.0 lbs.	Inc.
<b>Exhaust</b>				
	IX7	Single horizontal with DPF/SCR exhaust system	0.0 lbs.	Inc.
<b>Front Axle</b>				
	ID2	"I"-beam rated at 6,830 lbs. Includes integral hydraulic power steering. Ratio 18.8-20.9:1.	0.0 lbs.	Inc.
<b>Front Suspension</b>				
	ID8	8440 lbs. Capacity semi elliptical tapered leaf spring. Includes shock absorbers and stabilizer bar	0.0 lbs.	Inc.
<b>Front Wheels</b>				
	IB9	19.5" x 6", 6-hole disc, painted white	0.0 lbs.	Inc.

Current report content is based on data as of 2018-05-18 04:51:47. Any performance-related calculations are offered solely as guidelines. Actual vehicle performance will depend on your operating conditions. All information, specifications and pricing in this application are based on the latest information available. Isuzu Commercial Truck of America, Inc. reserves the right to discontinue or change, at any time, without prior notice, the pricing, specifications, options, materials, equipment, design and models.



# LEE-SMITH ISUZU TRUCK

Ralph Ashford, Jr | 423-648-6310 | aashford@lee-smith.com

CITY OF CHATTANOOGA BID #305105 (2019 NPR-XD Cab Chassis, NY1 109", 16,000 GVWR. White, In rail fuel tank with power windows, power door locks and air conditioning)

## Selected Model and Options

	Code	Description	Weight	MSRP
<b>Front Tires</b>				
	XTN/R3M	225/70R19.5F (12 ply) tubeless Radial, all season	0.0 lbs.	Inc.
<b>Rear Suspension</b>				
	I9K	14,308 lbs. capacity. Semi-elliptical main and auxiliary multi-leaf springs. Includes shock absorbers.	0.0 lbs.	Inc.
<b>Rear Axle</b>				
	I36	R040, single-speed, 11,020 lb. capacity with oil lubricated rear wheel bearings.	0.0 lbs.	Inc.
<b>Ratio</b>				
	099	4.777	0.0 lbs.	Inc.
<b>Rear Wheels</b>				
	IC1	19.5" x 6", 6-hole disc, painted white	0.0 lbs.	Inc.
<b>Rear Tires</b>				
	YTN/S3M	225/70R19.5F (12 ply) tubeless Radial, all season tread.	0.0 lbs.	Inc.
<b>Fuel Tank</b>				
	IF9	30 gal. rectangular fuel tank. Mounted between frame rail through the rail fuel fill. Fuel water separator with dash mounted warning light.	0.0 lbs.	Inc.
<b>Seat</b>				
	AQB	Driver seat is reclining high back. Two single occupant fold down seats with tray backs.	0.0 lbs.	Inc.
<b>Brakes</b>				
	K40	Butterfly valve type exhaust brake	0.0 lbs.	Inc.
	IR8	Dual circuit, vacuum assisted hydraulic with EBD (Electronic Brake Distribution). Disc front and self-adjust outboard mounted drum rear. Mechanical, transmission mounted parking brake. Non-asbestos semi metallic linings are standard. 4 channel anti-lock brake system.	0.0 lbs.	Inc.
<b>Power Windows &amp; Door Locks</b>				
	IL0	Yes	0.0 lbs.	Inc.
<b>Radio</b>				
	IL7	AM / FM / CD Stereo Radio	0.0 lbs.	Inc.
<b>Floor Mats</b>				
	IQ6	Standard Floor Mats	0.0 lbs.	Inc.
<b>Additional Options</b>				
	IF6	Fire Extinguisher and Triangle Kit mounted in rear organizer on standard cab and under rear seat on crew cab	19.0 lbs.	\$88.00
	IU2	Mirror Bracket for 102" wide body	1.0 lbs.	\$136.00

Current report content is based on data as of 2018-05-18 04:51:47. Any performance-related calculations are offered solely as guidelines. Actual vehicle performance will depend on your operating conditions. All information, specifications and pricing in this application are based on the latest information available. Isuzu Commercial Truck of America, Inc. reserves the right to discontinue or change, at any time, without prior notice, the pricing, specifications, options, materials, equipment, design and models.



# LEE-SMITH ISUZU TRUCK

Ralph Ashford, Jr | 423-648-6310 | aashford@lee-smith.com

CITY OF CHATTANOOGA BID #305105 (2019 NPR-XD Cab Chassis, NY1 109", 16,000 GVWR. White, In rail fuel tank with power windows, power door locks and air conditioning)

## Selected Model and Options

Code	Description	Weight	MSRP
IV8	Seat Covers standard cab	6.0 lbs.	\$280.00
V22	Chrome Grille	1.0 lbs.	\$400.00
IH2	Engine emergency shutdown system HWT, LWL, LOP	0.0 lbs.	\$100.00
I8L	High visiblity seat belt (red color, driver and RH passenger seat)	0.0 lbs.	\$184.00
I0M	Cold weather package (block heater and heated fuel filter)	1.0 lbs.	\$236.00
<b>Accessories</b>			
IX2	Rear body dome lamp switch	0.1 lbs.	Inc.
8RP	AM/FM/CD radio with Aux Input/USB port and Bluetooth RPO	0.0 lbs.	Inc.
<b>Totals</b>			
	Base Price		\$54,156.00
	Destination Charge		\$1,125.00
	DEF Fill Charge		\$10.00
	Total Options Price		\$2,696.00
	Tire Weight Tax		\$7.94
	<b>Total</b>		<b>\$57,994.94</b>

Current report content is based on data as of 2018-05-18 04:51:47. Any performance-related calculations are offered solely as guidelines. Actual vehicle performance will depend on your operating conditions. All information, specifications and pricing in this application are based on the latest information available. Isuzu Commercial Truck of America, Inc. reserves the right to discontinue or change, at any time, without prior notice, the pricing, specifications, options, materials, equipment, design and models.



# LEE-SMITH ISUZU TRUCK

Ralph Ashford, Jr | 423-648-6310 | aashford@lee-smith.com

CITY OF CHATTANOOGA BID #305105 (2019 NPR-XD Cab Chassis, NY1 109", 16,000 GVWR. White, In rail fuel tank with power windows, power door locks and air conditioning)

## Quote Worksheet

	MSRP
Base Price	\$54,156.00
Destination Charge	\$1,125.00
DEF Fill Charge	\$10.00
Total Options	\$2,696.00
<b>Subtotal</b>	<b>\$57,987.00</b>
New Item	\$0.00
<b>Subtotal Additional Equipment</b>	<b>\$0.00</b>
BODY SWAP FROM OLD CHASSIS TO NEW CHASSIS	\$1,105.50
500# TOMMY LIFT W/ALUMINUM DECK & LABOR INSTALLED ON VAN BODY	\$5,778.75
BACK UP CAMERA	\$530.25
NMO-RADIO-CABLE AND LABOR	\$808.00
TIRE SWAP OUT TO MICHELIN TIRES	\$2,525.00
SOFTWARE FOR DIAGNOSTICS	\$7,839.00
SHOP PERSONNEL TRAINING DIAGNOSTICS	\$1,111.00
BACKUP ALARM SMART REVERSING WHITE SOUND	\$126.25
LABOR TO INSTALL BACKUP ALARM	\$150.75
FREIGHT FOR DIAGNOSTICS & OTHER	\$151.50
PAINT FRAME RAILS VIPER RED	\$4,422.00
SUBSCRIPTION SERVICE FOR DIAGNOSTICS FOR 3 YEARS. (\$900.00 PER YEAR)	\$2,700.00
FIRST AID KIT	\$50.00
<b>Subtotal Miscellaneous Equipment</b>	<b>\$27,298.00</b>
<b>Pre-Tax Subtotal</b>	<b>\$85,285.00</b>
Less Customer Discount	(\$-13,588.00)
<b>Subtotal Discount</b>	<b>(\$-13,588.00)</b>
<b>Taxable Price</b>	<b>\$71,697.00</b>
Sales Tax	0% \$0.00
Tire Weight Tax	\$7.94
<b>Subtotal Taxes</b>	<b>\$7.94</b>
<b>Subtotal Post-Tax Adjustments</b>	<b>\$0.00</b>
Less Post-tax Customer Discount	\$0.00
<b>Subtotal Discount</b>	<b>\$0.00</b>

Current report content is based on data as of 2018-05-18 04:51:47. Any performance-related calculations are offered solely as guidelines. Actual vehicle performance will depend on your operating conditions. All information, specifications and pricing in this application are based on the latest information available. Isuzu Commercial Truck of America, Inc. reserves the right to discontinue or change, at any time, without prior notice, the pricing, specifications, options, materials, equipment, design and models.



# LEE-SMITH ISUZU TRUCK

Ralph Ashford, Jr | 423-648-6310 | aashford@lee-smith.com

CITY OF CHATTANOOGA BID #305105 (2019 NPR-XD Cab Chassis, NY1 109", 16,000 GVWR. White, In rail fuel tank with power windows, power door locks and air conditioning)

## Quote Worksheet

Total Sales Price \$71,704.94

\_\_\_\_\_  
Dealer Signature/Date

\_\_\_\_\_  
Customer Signature/Date

Current report content is based on data as of 2018-05-18 04:51:47. Any performance-related calculations are offered solely as guidelines. Actual vehicle performance will depend on your operating conditions. All information, specifications and pricing in this application are based on the latest information available. Isuzu Commercial Truck of America, Inc. reserves the right to discontinue or change, at any time, without prior notice, the pricing, specifications, options, materials, equipment, design and models.



# NPR-HD DIESEL

## STANDARD CAB

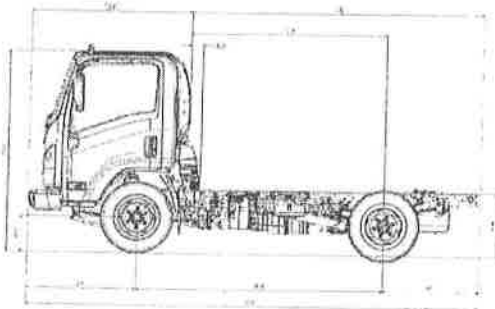
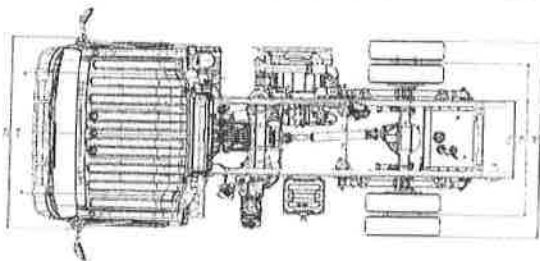

Wheelbase (in.)	Cab to Axle (in.)	Cab to End of Frame (in.)	Back of Cab (in.)	Overall Length (in.)	Body Length (ft.)	Overall Width (in.)	Axle Width (in.)	Overall Height (in.)
1090	86.5	129.6	7.7	200.5	10-12	81.3	65.6	90.8
132.5	110.0	153.1	7.7	224.0	14	81.3	65.6	90.8
150.0	127.5	170.6	10.2	241.5	16-18	81.3	65.6	90.8
176.0	153.5	196.6	10.2	267.5	18-20	81.3	65.6	90.8

<b>GVWR/GCWR</b>	14,500/20,500 lbs.
<b>BODY/PAYLOAD ALLOWANCE</b>	8,339-8,536 lbs.
<b>GAWR</b> Front Rear	5,360 lbs. 9,880 lbs.
<b>FRONT AXLE CAPACITY</b>	6,830 lbs.
<b>REAR AXLE CAPACITY</b> Ratio	11,020 lbs. 4.555
<b>SUSPENSION F/R SPRINGS</b> Capacity	Tapered/Multi-Leaf 6,830/9,880 lbs.
<b>FRAME</b> Section Modulus Resistance Bending Moment	7.20 in. <sup>3</sup> 316,800 lb.-in.
<b>SERVICE BRAKES</b> Front/Rear	Vacuum/Hydraulic with 4-Channel ABS Disc/Drum
<b>EXHAUST BRAKE</b>	Standard
<b>TRANSMISSION</b>	Aisin A465 6-speed auto. with double overdrive and lock-up 2 <sup>nd</sup> -6 <sup>th</sup> gears
<b>ENGINE</b>	Isuzu 4HK1-TC turbocharged intercooled diesel
Displacement Engine Power Engine Torque	5.2L (317 in. <sup>3</sup> ) 215 hp @ 2,500 rpm 452 lb.-ft. @ 1,850 rpm
<b>OIL LEVEL INDICATOR</b>	Dash-mounted oil level check switch and light
<b>LIMITED SLIP DIFFERENTIAL</b>	Optional
<b>ALTERNATOR</b>	140-amp
<b>BATTERIES</b>	2 Maintenance-Free 750-CCA
<b>TIRES LRR</b> (Low Rolling Resistance)	215/85R16E (10-pr) Standard
<b>STEERING</b>	Integral Hydraulic Power
<b>STEERING COLUMN</b>	Tilt and Telescopic
<b>FUEL TANK</b> Standard Optional	30 gal. in-rail 33 gal. side mount (176" WB Only)
<b>FUEL/WATER SEPARATOR</b>	Dual fuel filter with dash mounted indicator light

### 2019 ISUZU N-SERIES DIESEL WARRANTY COVERAGE AT A GLANCE

Vehicle Coverage	Warranty Limitations (Time or Mileage, Whichever Comes First)*		Percentage of Dealer's Normal Charge Paid by Owner	
	Time in Years	Vehicle Miles	Parts	Labor
Basic	0-3 Years	Unlimited	No Charge	No Charge
Engine	0-3 Years	Unlimited	No Charge	No Charge
• Transmission • Drive Axle • Driveshaft • Front Axle I-Beam • Crossmembers • Flywheel Housing • Clutch Housing • Frame Rails	0-3 Years	Unlimited	No Charge	No Charge
Engine Emissions Control System - Federal	0-3 Years	Unlimited	No Charge	No Charge
Tires	0-5 Years	0-100,000	50%	50%
Corrosion (Rust Through)	0-5 Years	0-100,000	No Charge	No Charge

\*The warranty coverages are determined by the mileage of the vehicle and the number of years from the delivery date. See your authorized Isuzu dealer for warranty details.



- Home
- Login ▾
- Shopping ▾
- Links
- Contact
- (0)

Providing diagnostic tools for Isuzu commercial vehicles.

## Shopping

Home / Shopping / Isuzu Diagnostic Service System (IDSS)

<ul style="list-style-type: none"> <li>Service Information</li> <li>Isuzu Diagnostic Tools</li> <li>Replacement Parts</li> <li>Tablet Accessories</li> <li>Free Downloads</li> <li>Training Materials</li> <li>Option Content Tool</li> </ul>	<div style="display: flex; align-items: center;"> <h3>IDSS Diagnostic Service Tablet</h3> </div> <div style="margin-top: 10px;"> <ul style="list-style-type: none"> <li><input checked="" type="checkbox"/> What is IDSS?</li> <li><input checked="" type="checkbox"/> What's included?</li> <li><input checked="" type="checkbox"/> Vehicle coverage</li> </ul> </div> <div style="margin-top: 10px;"> <p><b>The Isuzu Diagnostic Service System (IDSS) Tablet</b> is Isuzu's next generation all-in-one hardware and software solution for diagnosis and repair of Isuzu commercial vehicles.</p> <p>The tablet provides users with on-vehicle diagnostic capability, as well as features similar to that of a PC, including:</p> <ol style="list-style-type: none"> <li>1. Embedded Windows 7</li> <li>2. 12.5" touch screen</li> <li>3. 2 GB RAM</li> <li>4. 64 GB hard drive</li> <li>5. 1.8 GHz Dual Core CPU</li> <li>6. Two-way camera with flash</li> <li>7. Virtual keyboard with ON/OFF button</li> <li>8. Integrated speakers</li> <li>9. 2 USB ports</li> <li>10. Ethernet port</li> <li>11. 26-pin DLC connector</li> <li>12. Onboard WIFI</li> <li>13. Microphone and speaker jacks</li> <li>14. External monitor connector</li> <li>15. 6 hour battery life</li> </ol> <p>The IDSS II tablet arrives pre-installed with IDSS II software, which contains service information (including electronic troubleshooting manual/wiring diagrams), full-featured scan tool, service programming, and bulletins to support all Isuzu manufactured products.</p> <p>The IDSS II tablet is compatible with the following protocols:</p> <ol style="list-style-type: none"> <li>1. J1939</li> <li>2. CAN</li> <li>3. J1708</li> <li>4. NRZ</li> <li>5. LIN</li> <li>6. KW2000</li> <li>7. FlexRay</li> <li>8. ISO 9141</li> <li>9. J1850 VPW, PWM</li> <li>10. ISO 15765</li> </ol> </div>
---	---

 When ordering this item, please allow 1 to 2 business days for processing prior to shipment.

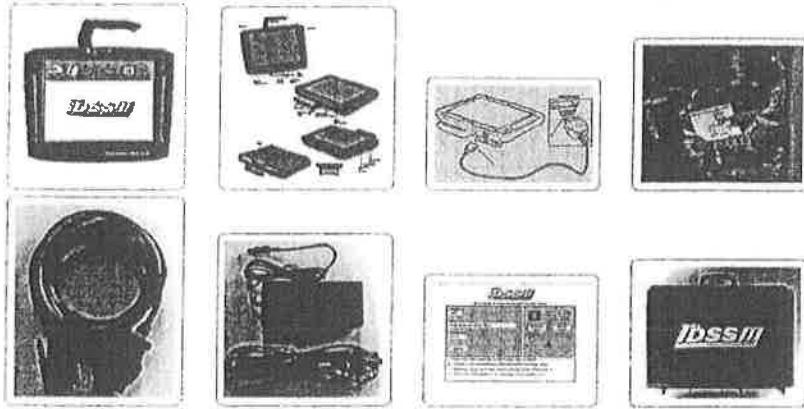

 **IDSS Interface Module Kit**

What Is IDSS?

The **Isuzu Diagnostic Service System (IDSS)** is an all-in-one hardware and software solution for diagnosis and repair of Isuzu commercial vehicles.

What's included?

This package contains service information (including electronic troubleshooting manual/wiring diagrams), full-featured scan tool, service programming, and bulletins to support all Isuzu manufactured products.

Vehicle coverage

The IDSS software is designed for use with the IDSS interface module, Included with this kit.

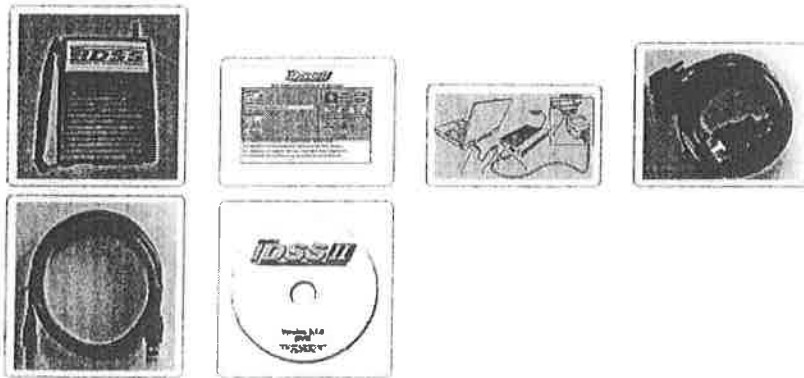

## ISUZU EXTENDED WARRANTY COVERAGE

Isuzu is committed to assuring your satisfaction with your commercial truck. Your authorized Isuzu dealer also wants you to be completely satisfied and invites you to return for all your service needs, both during and after the standard and Extended Warranty periods.

While any authorized Isuzu N-Series dealer can perform standard and Extended Warranty service, we recommend that you return to the dealership that sold you your vehicle because of their continued and personal interest in you. If you are traveling, move or did not obtain your truck from an authorized dealership, any authorized Isuzu dealer can provide standard and Extended Warranty service for you.

Considering the investment you have made in your commercial truck, we know you will want to operate and maintain it properly. Therefore, we urge you to follow the instructions and recommendations contained in your Owner's Manual.

Should you ever encounter a problem that is not resolved, talk to a member of dealer management. If a problem persists, follow the procedures outlined in your New Vehicle Warranty Booklet.

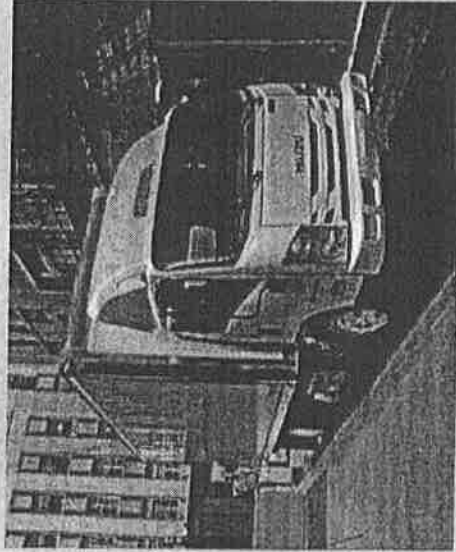

**ISUZU**  
TRUCK

# EXTENDED WARRANTY

## N-SERIES DIESEL

### ROADSIDE ASSISTANCE

Isuzu N-Series Diesel trucks are built to be the highest quality, most reliable trucks in the industry. That's why we back them with one of the strongest roadside assistance programs ever offered for Medium Duty Trucks.

With ANY Isuzu vehicle warranty, if your Isuzu N-Series Diesel truck experiences a mechanical breakdown anywhere in the United States, just call our 24-hour, toll-free number 866-441-9659 anytime day or night, 365 days a year. A service vehicle will be dispatched to provide minor roadside repairs or tow your truck to the nearest Isuzu dealer for service.



[ISUZUCV.COM](http://ISUZUCV.COM)

© 2018 ISUZU COMMERCIAL TRUCK OF AMERICA, INC.

TM 10235 (04/18)

## EXTENDED WARRANTY

- **ENGINE**

Cylinder block, cylinder head, oil pan, oil cooler, thermostat housing, flywheel, intake manifolds, and the following internal parts: oil pump, pistons with rings, liners, crankshaft and bearings, connecting rods and bearings, head bolts, cylinder head gasket, intake and exhaust valves, rocker arm assembly, camshaft and bearings.

- **TRANSMISSION**

Transmission case and all internal parts (excludes Allison transmissions).

- **DRIVE AXLE**

Differential, axle shafts, all seals and bearings.

- **ROADSIDE ASSISTANCE**

Warranty coverages are determined by the mileage of the vehicle and the number of months from delivery date, whichever comes first.

## EXTENDED WARRANTY PLUS

(Includes Extended Warranty)

- **FUEL INJECTORS**

Fuel injectors, fuel pressure limiter, fuel injection pump, fuel rail pressure sensor, fuel temperature sensor, common fuel rail and high pressure lines.

- **TURBOCHARGER**

- **ALTERNATOR**

- **STARTER**

Starter, starter drive assembly, starter motor assembly.

- **WATER PUMP**

- **REAR DRIVE AXLE**

- **FRONT I-BEAM AXLE**

- **CROSSMEMBERS**

## AFTERTREATMENT WARRANTY PLUS

(Includes Extended Warranty and Extended Warranty Plus)

- **DIESEL PARTICULATE FILTER (DPF) FUEL INJECTOR**

- **DPF FUEL PRESSURE SENSOR**

- **PARTICULATE MATTER SENSOR**

- **EXHAUST TEMPERATURE SENSOR (POSITION 1)**

- **EXHAUST TEMPERATURE SENSOR (POSITION 2)**

- **FRONT EXHAUST PIPE**

- **DIESEL PARTICULATE FILTER**

- **EXHAUST CATALYTIC CONVERTER (DOC)**

- **EXHAUST PRESSURE DIFFERENTIAL SENSOR**

- **DIESEL EXHAUST FLUID (DEF) LINE (TANK TO PUMP)**

- **DEF LINE (PUMP TO INJECTOR)**

- **DEF HEATER VALVE**

- **DEF CONTROL MODULE**

- **DEF SUPPLY PUMP**

- **DEF BACKFLOW VALVE**

- **DEF INJECTOR**

- **DEF SENSOR (NO LEVEL)**

- **SCR CATALYST**

- **SCR EXHAUST TEMPERATURE SENSOR**

- **NOX SENSOR #1**

- **NOX SENSOR #2**

- **EMISSIONS SYSTEM WIRING (AFTERTREATMENT ONLY)**

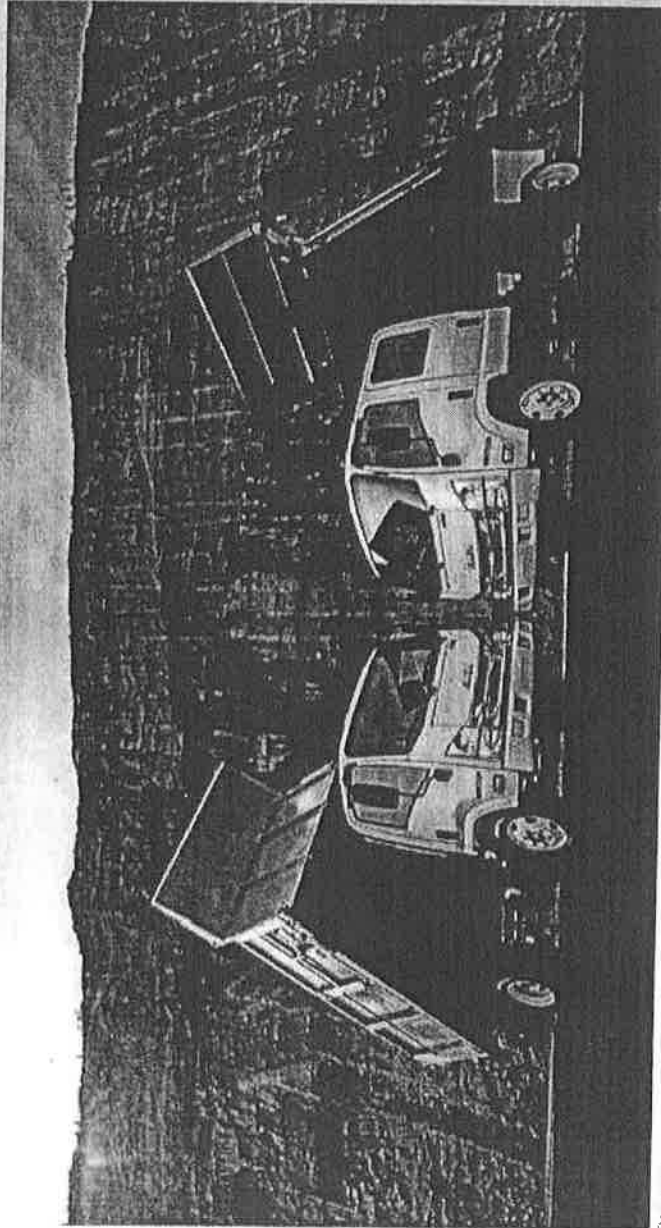

The warranty coverages are determined by the mileage of the vehicle and the number of years from the delivery date. See your authorized Volvo dealer for warranty details.





# City of Chattanooga

Mayor Andy Berke

May 30, 2018

Mr. Justin Holland  
Administrator, Public Works Department  
Waste Resource Division  
1250 Market Street, Suite 2100  
Chattanooga, TN 37402

**Subject: Contract Renewal of Blanket PO No. 535097 – Grounds Maintenance/Enterprise Industrial Park – Parks Division – Public Works Department**

Dear Mr. Holland:

Council approval is recommended to renew Blanket PO No. 535097 for Grounds Maintenance/Enterprise Industrial Park, Parks Division, Public Works Department. The City of Chattanooga is renewing the second (2<sup>nd</sup>) and last renewal option for twelve (12) months through May, 2019, for an estimated annual amount of \$35,000. A copy of the signed letter from vendor, and a copy of the contract is enclosed.

The original invitation to bid was sent to eight (8) vendors as well as formally advertised. Bids were received from five (5) vendors. Bids are retained on file in the Purchasing Office for your review upon request.

I recommend renewing Blanket PO No. 535097 for Grounds Maintenance/Enterprise Industrial Park to Special Touch Lawn Service, 4608 Woodmore View Circle, Chattanooga, TN 37411

Respectfully yours,

Bonnie Woodward  
Director of Purchasing

BW/mlm

Attachments



# City of Chattanooga

Mayor Andy Berke

May 21, 2018

Special Touch Lawn Service  
 Attn: Mike Jones  
 4608 Woodmore View Circle  
 Chattanooga, TN 37411

Subject: Renewal For Blanket Contract 535097 – Grounds Maintenance/Enterprise  
 Industrial Park – Public Works/Parks Division

Dear Mr. Jones:

The City of Chattanooga would like to exercise the final option to renew the above contract for an additional (12) twelve month term under the same terms and conditions.

By mutual agreement, the extended contract date will be May 31, 2019. Please sign below and return by fax or e-mail if you are in agreement with the contract renewal.

As always, we appreciate the quality of service you have provided and look forward to working with you in the future.

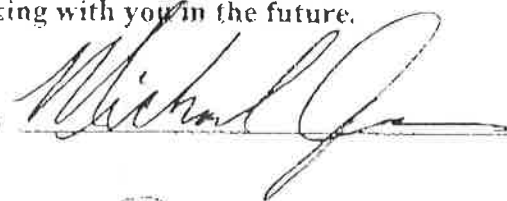
Signed: 



Dedra Partridge – Buyer  
 City of Chattanooga/Purchasing  
 101 East 11<sup>th</sup> Street City Hall, G 13  
 Chattanooga, TN 37402

Tele: (423) 643-7237  
 Fax: (423) 643-7244  
 dpartridge@chattanooga.gov

# Purchase Order BLANKET



**City of Chattanooga**  
101 East 11th Street, Suite G13  
Chattanooga, TN 37402

<b>V E N D O R</b>	Vendor Number: 752240 Vendor Alternate ID: 5625  Special Touch Lawn Service 4608 Woodmore View Circle Chattanooga, TN 37411
--	--

PO Date: 08-OCT-15 Buyer: William Tucker FOB: DESTINATION Terms: Immediate	<b>Purchase Order Number</b> <b>535097</b>  INVOICES: Direct invoices in DUPLICATE to the Invoice address shown below.
---	---

<b>S H I P T O</b>	
--	--

<b>I N V O I C E</b>	Accounts Payable Division City of Chattanooga 101 East 11th Street, Suite 101 Chattanooga, TN 37402
--	--

Requestor		Requisition Number		Bid Number	
Line Nbr	Item ID - Item Description	Quantity	Unit	Unit Price	Total
Requisition No. 121324 Ordering Dept.: Public Works Buyer: William Tucker Telephone: 423-643-7238 Fax: 423-643-7244 Email: tucker_w@chattanooga.gov .....					
Items Being Purchased: Grounds Maintenance at Enterprise South Industrial Park .....					
This shall be a twelve (12) month blanket contract to supply Grounds Maintenance Services at Enterprise South Industrial Park as needed by agencies of the City of Chattanooga. The contract term may be renewed for two (2) additional twelve (12)-month terms under the same terms and conditions by mutual agreement. The City of Chattanooga and the Contractor may bilaterally extend the Contract by providing written confirmation of agreement by both parties at least 30 days prior to the Contract's current expiration date. .....					
Public Works Administration Development Resource Center, Suite 2100 1250 Market Street Chattanooga, TN 37402  Contact: David Johnson, Tel: 423-643-6095 .....					
Vendor Contact Information:  Vendor Name: Special Touch Lawn Care Contact Person: Michael Jones Tel.: 423-760-2380 Fax: 423-629-0553 Email: jones8654@epbf.com Street Address: 4608 Woodmore View Circle City, State, Zip: Chattanooga, TN 37411 .....					

\*\*\*\*\* NOTICE \*\*\*\*\*

This Purchase Order ("Agreement") is a binding agreement between the City of Chattanooga and the Vendor. This Purchase Order shall be governed by the following documents: (1) Purchase Order; (2) City of Chattanooga Purchase Order Standard Terms and Conditions; (3) Vendor's response to the bid or quotation; and (4) terms and conditions set forth in the bid or quotation, each of which is hereby incorporated herein by reference and becomes a part of this Agreement. In the event any conflict of terms arises, the terms controlling the Agreement shall be in the order provided hereinabove. This Purchase Order is valid only when signed or electronically approved by the Finance Officer.

Electronic approval is on record in the purchasing information system which asserts that unencumbered appropriation is available to meet the expenditure covered by this Purchase Order; and further authorizes payment upon proper certification of receipt of goods and/or services.



# Purchase Order BLANKET



**City of Chattanooga**  
101 East 11th Street, Suite G13  
Chattanooga, TN 37402

<b>V E N D O R</b>	Vendor Number: 752240 Vendor Alternate ID: 5625  Special Touch Lawn Service 4608 Woodmore View Circle Chattanooga, TN 37411
--	--

PO Date: 08-OCT-15 Buyer: William Tucker FOB: DESTINATION Terms: Immediate	<b>Purchase Order Number 535097</b>  INVOICES: Direct invoices in DUPLICATE to the Invoice address shown below.
---	---

<b>S H I P T O</b>	
--	--

<b>I N V O I C E</b>	Accounts Payable Division City of Chattanooga 101 East 11th Street, Suite 101 Chattanooga, TN 37402
--	--

Requestor			Requisition Number		Bid Number
Line Nbr	Item ID - Item Description	Quantity	Unit	Unit Price	Total
1	Monthly service - Volkswagen Dr, Discovery Dr, Park Entrances	0.00	Month	\$ 1,512.5000	\$ 0.00
2	Monthly service - Hickory Valley Rd, Ferdinand Piech Way, Bonny Oaks Dr embankments	0.00	Month	\$ 687.5000	\$ 0.00

**TOTAL: \$ .00**

\*\*\*\*\* NOTICE \*\*\*\*\*

This Purchase Order ("Agreement") is a binding agreement between the City of Chattanooga and the Vendor. This Purchase Order shall be governed by the following documents: (1) Purchase Order; (2) City of Chattanooga Purchase Order Standard Terms and Conditions; (3) Vendor's response to the bid or quotation; and (4) terms and conditions set forth in the bid or quotation, each of which is hereby incorporated herein by reference and becomes a part of this Agreement. In the event any conflict of terms arises, the terms controlling the Agreement shall be in the order provided hereinabove. This Purchase Order is valid only when signed or electronically approved by the Finance Officer.

Electronic approval is on record in the purchasing information system which asserts that unencumbered appropriation is available to meet the expenditure covered by this Purchase Order, and further authorizes payment upon proper certification of receipt of goods and/or services.



# City of Chattanooga

Mayor Andy Berke

May 30, 2018

Mr. Justin Holland  
Administrator, Public Works Department  
City Wide Services  
1250 Market Street, Suite 2100  
Chattanooga, TN 37402

**Subject: 164748 / 304999 – River Sand – City Wide Services – Public Works Department**

Dear Mr. Holland:

Council approval is recommended to issue two (2) blanket contracts for River Sand, City Wide Services, Public Works Department. The contract will be for twelve (12) months with the option to renew for two (2) additional twelve (12) month terms. The estimated annual expenditure for this contract is \$60,000 annually.

The invitation to bid was sent to four (4) vendors as well as formally advertised. Bids were received from two (2) vendors shown below. Bids are retained on file in the Purchasing Office for your review upon request.

#### Vendors

Ramsey Trucking, Inc  
McKinnley Excavating

I recommend awarding the blanket contracts for River Sand to McKinnley Excavating as the primary vendor, 411 West 21st Street, Chattanooga, TN 37408 & Ramsey Trucking, Inc as the secondary vendor, 731 Pineville Road, Chattanooga, TN 37405, as the best complete bids meeting specifications for the City of Chattanooga.

Respectfully yours,

Bonnie Woodward  
Director of Purchasing

BW/mlm

Attachments

					Bid Tabulation - 164748/304999				
					River Sand				
					Ramsey Trucking, Inc.		McKinnley Excavating		
Item	Quantity	Unit	Unit Price	Total	Unit Price	Total			
1	450	Ton	\$33.00	\$14,850.00	\$27.00	\$12,150.00			
2	450	Ton	\$35.00	\$15,750.00	\$27.00	\$12,150.00			
Total				\$30,600.00		\$24,300.00			

# BID SOLICITATION



**City of Chattanooga**  
 101 East 11th Street, Suite G13  
 Chattanooga, TN 37402

<b>BID OPENING DATE AND TIME:</b> 25-MAY-18 at 2:00 PM  <b>BID NUMBER: 304999</b>
<b>BUYER:</b> PHONE #: (423) 643-7230 <b>DELIVERY REQUIRED:</b>

SEALED BIDS

Mail or submit two (2) signed copies of bid form to this office in the enclosed envelope. Retain one copy for your file.

V  
E  
N  
D  
O  
R

RFQ

M  
A  
I  
L  
T  
O

City of Chattanooga  
 101 East 11th Street, Suite G13  
 Chattanooga, TN 37402

Item	Class-Item	Quantity	Unit	Unit Price	Total
Requisition No.: 164748 Ordering Dept.: Public Works/City Wide Services Division Buyer: Dedra Partridge Phone No.: (423) 643-7237  Items Being Purchased: River Sand For Pickup and Delivery  ATTACHMENTS: Vendor Disclosure and Acknowledgement Affirmative Action Plan Requirements For Insurance Coverage City of Chattanooga (COC) Terms and Conditions posted on Website <a href="http://www.chattanooga.gov/general-services/purchasing/standard-terms-and-conditions">http://www.chattanooga.gov/general-services/purchasing/standard-terms-and-conditions</a> If you can't download call buyer for a copy.  This Shall Be A Twelve (12) Month Blanket Contract To Supply River Sand For Pickup and Delivery. The Contract Term May Be Renewed For Two (2) Additional Twelve (12) Month Term Under The Same Terms And Conditions By Mutual Agreement. The City Of Chattanooga And The Contractor May Bilaterally Extend The Contract By Providing Written Confirmation Of Agreement By Both Parties At Least 30 Days Prior To The Contract's Current Expiration Date Into Any Successive Term As Provided Herein.  QUANTITIES ARE ESTIMATES ONLY THE CITY OF CHATTANOOGA SHALL GUARANTEE NO MINIMUM OR MAXIMUM AMOUNT PURCHASED DURING THE LIFETIME OF THE CONTRACT.  *** BID MUST BE RECEIVED NO LATER THAN *** *** 2:00 PM EST ON May 25, 2018 ***  NOTE: ALL BIDS MUST BE SIGNED All bids received are subject to the terms and conditions contained herein and as listed in the above referenced website. The undersigned Bidder acknowledges having received, reviewed, and agrees to be bound to these terms and conditions, unless specific written exceptions are otherwise stated.  Any manufacturer;s names, trade names, brand names, or catalog numbers used in the specifications are for the purpose of describing and establishing general quality levels. Such references ar enot intended to be restrictive. Bids will be considered for any brand which meets or exceeds the quality of the specifications listed for any item.  The City of Chattanooga reserves the right to reject any and/or all bids, waive any informalities in the bids received, and to accept any bid which in its opinion may be for the best interest of the city.  The City of Chattanooga will be non-discriminatory in the purchase of all goods and services on the basis of race, color, or national origin.  **** NOTE **** PLEASE PROVIDE US WITH THE FOLLOWING INFORMATION: Company Name <u>Mckinnley Supply</u>					

# BID SOLICITATION



City of Chattanooga  
 101 East 11th Street, Suite G13  
 Chattanooga, TN 37402

<b>BID OPENING DATE AND TIME:</b> 25-MAY-18 at 2:00 PM  <b>BID NUMBER: 304999</b>
<b>BUYER:</b> PHONE #: (423) 643-7230 DELIVERY REQUIRED:

SEALED BIDS

Mail or submit two (2) signed copies of bid form to this office in the enclosed envelope. Retain one copy for your file.

V  
E  
N  
D  
O  
R

RFQ

M  
A  
I  
L  
I  
N  
G

City of Chattanooga  
 101 East 11th Street, Suite G13  
 Chattanooga, TN 37402

Item	Class-Item	Quantity	Unit	Unit Price	Total
Address <u>411 W. 21st</u> <u>Chattanooga TN 37408</u> Phone/Toll-Free No. <u>423-321-8695</u> Fax No. _____ eMail Address <u>joe@digechattanooga.com</u> Contact Person's Name <u>Sarah Simpson</u> Estimated Delivery _____ Minority-Owned Business _____ Small Business <input checked="" type="checkbox"/> Veteran <input checked="" type="checkbox"/> Minority Woman-Owned Business _____ Disabled Veteran _____ Woman-Owned Business <input checked="" type="checkbox"/> **** ALL ITEMS MUST BE QUOTED F.O.B. DESTINATION ****					

**NOTE: ALL BIDS RECEIVED ARE SUBJECT TO THE TERMS AND CONDITIONS**

ALL BIDS MUST BE SIGNED - The undersigned offers the above quoted prices under the conditions contained herein.

The City is Exempt from all Federal and State Tax.  
 Bids will be received at the above mentioned address.

COMPANY: McKinley Supply  
 SIGNATURE: [Signature]  
 NAME AND TITLE: Sarah Simpson  
Manager

TERMS OF PAYMENT: Net 7  
 TELEPHONE NUMBER: 423-321-8695

# BID SOLICITATION



City of Chattanooga  
 101 East 11th Street, Suite G13  
 Chattanooga, TN 37402

<b>BID OPENING DATE AND TIME:</b> 25-MAY-18 at 2:00 PM  <b>BID NUMBER: 304999</b>
<b>BUYER:</b> PHONE #: (423) 643-7230 <b>DELIVERY REQUIRED:</b>

SEALED BIDS

Mail or submit two (2) signed copies of bid form to this office in the enclosed envelope. Retain one copy for your file.

V  
E  
N  
D  
O  
R

RFQ

M  
A  
I  
L  
T  
O

City of Chattanooga  
 101 East 11th Street, Suite G13  
 Chattanooga, TN 37402

Item	Class-Item	Quantity	Unit	Unit Price	Total
1	River Sand - Picked Up - Per Ton	450	Ton	<u>27</u>	<u>12,150</u>
2	River Sand - Delivered - Per Ton	450	Ton	<u>27</u>	<u>12,150</u>

NOTE: ALL BIDS RECEIVED ARE SUBJECT TO THE TERMS AND CONDITIONS

ALL BIDS MUST BE SIGNED – The undersigned offers the above quoted prices under the conditions contained herein.

The City is Exempt from all Federal and State Tax.  
 Bids will be received at the above mentioned address.

COMPANY: \_\_\_\_\_

TERMS OF PAYMENT: \_\_\_\_\_

SIGNATURE: \_\_\_\_\_

TELEPHONE NUMBER: \_\_\_\_\_

NAME AND TITLE: \_\_\_\_\_

Chapter No. 817 (HB0261/SB0377). "Iran Divestment Act" enacted.  
Vendor Disclosure and Acknowledgement

By submission of this bid, each bidder and each person signing on behalf of any bidder certifies, and in the case of a joint bid each party thereto certifies as to its own organization, under penalty of perjury, that to the best of its knowledge and belief that each bidder is not on the list created pursuant to § 12-12-106.

(SIGNED)   
(PRINTED NAME) Sarah Simpson  
(BUSINESS NAME) McKinley Supply LLC  
(DATE) 5/18/18

For further information, please see website:

[https://www.tn.gov/assets/entities/generalservices/cpo/attachments/List\\_of\\_persons\\_pursuant\\_to\\_Tenn.\\_Code\\_Ann.\\_12-12-106,\\_Iran\\_Divestment\\_Act-July.pdf](https://www.tn.gov/assets/entities/generalservices/cpo/attachments/List_of_persons_pursuant_to_Tenn._Code_Ann._12-12-106,_Iran_Divestment_Act-July.pdf)

## Affirmative Action Plan.

The City of Chattanooga is an equal opportunity employer and during the performance of this Contract, the Contractor agrees to abide by the equal opportunity goals of the City of Chattanooga as follows

- 1 The Contractor will not discriminate against any employee or applicant for employment because of race, color, religion, sex, national origin, or handicap. The Contractor will take affirmative action to ensure that applicants are employed, and the employees are treated during employment without regard to their race, color, religion, sex, national origin, or handicap. Such action shall include, but not be limited to, the following: employment, upgrading, demotion, or transfer, recruitment or recruitment advertising, layoff or termination, rates of pay, or other forms of compensation, and selection for training, including apprenticeship. The Contractor agrees to post in conspicuous places, available to employees and applicants for employment, notices setting forth the provisions of this nondiscrimination clause.
- 2 The Contractor will, in all solicitations or advertisements for employees placed by or on behalf of the Contractor, state that all qualified applicants will receive consideration for employment without regard to race, color, religion, sex, national origin, or handicap
- 3 The Contractor will send to each labor union or representative of workers with which he/she has a collective bargaining agreement or other contract or understanding, a notice advising the said labor union or workers' representatives of the Contractor's commitments under this section, and shall post copies of the notice in conspicuous places available to employees and applicants for employment
- 4 In all construction contracts or subcontracts in excess of \$10,000 to be performed for the City of Chattanooga, any contractor and/or subcontractor is further required to file in duplicate within ten (10) days of being notified that it is the lowest responsible bidder, an affirmative action plan with the EEO Director of the City of Chattanooga. This plan shall state the Contractor's goals for minority and women utilization as a percentage of the work force on this project.
- 5 This Plan or any attachments thereto shall further provide a list of all employees annotated by job function, race, and sex who are expected to be utilized on this project. This plan or attachment thereto shall further describe the methods by which the Contractor or Subcontractor will utilize to make good faith efforts at providing employment opportunities for minorities and women.

During the term of this contract, the Contractor upon request of the City, will make available for inspection by the City of Chattanooga copies of payroll records, personnel documents and similar records or documents that may be used to verify the Contractor's compliance with these Equal Opportunity provisions.



- 6 The Contractor will include the portion of the sentence immediately preceding paragraph 1 and the provisions of paragraphs 1 through 6 in every subcontract so that such provisions will be requested of each subcontractor. The Contractor agrees to notify the City of Chattanooga of any subcontractor who refuses or fails to comply with these equal opportunity provisions. Any failure or refusal to comply with these provisions the Contractor and/or Subcontractor shall be a breach of this contract.

  
\_\_\_\_\_  
(Signature of Contractor)

  
\_\_\_\_\_  
(Title and Name of Construction Company)

  
\_\_\_\_\_  
(Date)

# BID SOLICITATION



**City of Chattanooga**  
 101 East 11th Street, Suite G13  
 Chattanooga, TN 37402

**BID OPENING DATE AND TIME:**  
 25-MAY-18 at 2:00 PM

**BID NUMBER:** 304999

---

**BUYER:**  
**PHONE #:** (423) 643-7230  
**DELIVERY REQUIRED:**

SEALED BIDS

Mail or submit two (2) signed copies of bid form to this office in the enclosed envelope. Retain one copy for your file.

**V**  
**E**  
**N**  
**D**  
**O**  
**R**

RFQ

**M** City of Chattanooga  
**A** 101 East 11th Street, Suite G13  
**I** Chattanooga, TN 37402  
**L**  
**T**  
**O**

Item	Class-Item	Quantity	Unit	Unit Price	Total
Requisition No.: 164748 Ordering Dept.: Public Works/City Wide Services Division Buyer: Dedra Partridge Phone No.: (423) 643-7237 Items Being Purchased: River Sand For Pickup and Delivery ATTACHMENTS: Vendor Disclosure and Acknowledgement Affirmative Action Plan Requirements For Insurance Coverage City of Chattanooga (COC) Terms and Conditions posted on Website <a href="http://www.chattanooga.gov/general-services/purchasing/standard-terms-and-conditions">http://www.chattanooga.gov/general-services/purchasing/standard-terms-and-conditions</a> If you can't download call buyer for a copy. This Shall Be A Twelve (12) Month Blanket Contract To Supply River Sand For Pickup and Delivery. The Contract Term May Be Renewed For Two (2) Additional Twelve (12) Month Term Under The Same Terms And Conditions By Mutual Agreement. The City Of Chattanooga And The Contractor May Bilaterally Extend The Contract By Providing Written Confirmation Of Agreement By Both Parties At Least 30 Days Prior To The Contract's Current Expiration Date Into Any Successive Term As Provided Herein. QUANTITIES ARE ESTIMATES ONLY THE CITY OF CHATTANOOGA SHALL GUARANTEE NO MINIMUM OR MAXIMUM AMOUNT PURCHASED DURING THE LIFETIME OF THE CONTRACT. *** BID MUST BE RECEIVED NO LATER THAN *** *** 2:00 PM EST ON May 25, 2018 *** NOTE: ALL BIDS MUST BE SIGNED All bids received are subject to the terms and conditions contained herein and as listed in the above referenced website. The undersigned Bidder acknowledges having received, reviewed, and agrees to be bound to these terms and conditions, unless specific written exceptions are otherwise stated. Any manufacturer;s names, trade names, brand names, or catalog numbers used in the specifications are for the purpose of describing and establishing general quality levels. Such references ar enot intended to be restrictive. Bids will be considered for any brand which meets or exceeds the quality of the specifications listed for any item. The City of Chattanooga reserves the right to reject any and/or all bids, waive any informalities in the bids received, and to accept any bid which in its opinion may be for the best interest of the city. The City of Chattanooga will be non-discriminatory in the purchase of all goods and services on the basis of race, color, or national origin. **** NOTE **** PLEASE PROVIDE US WITH THE FOLLOWING INFORMATION: Company Name <u>RAMSEY TRUCKING, INC.</u>					

# BID SOLICITATION



City of Chattanooga  
 101 East 11th Street, Suite G13  
 Chattanooga, TN 37402

<b>BID OPENING DATE AND TIME:</b> 25-MAY-18 at 2:00 PM  <b>BID NUMBER: 304999</b>
<b>BUYER:</b> PHONE #: (423) 643-7230 <b>DELIVERY REQUIRED:</b>

**SEALED BIDS**

Mail or submit two (2) signed copies of bid form to this office in the enclosed envelope. Retain one copy for your file.

V E N D O R	RFQ
----------------------------	-----

M A I L I T O	City of Chattanooga 101 East 11th Street, Suite G13 Chattanooga, TN 37402
---------------------------------	---

Item	Class-Item	Quantity	Unit	Unit Price	Total
Address <u>731 PINEVILLE ROAD</u> <u>CHATTANOOGA, TN 37405</u> Phone/Toll-Free No. <u>423-266-8237</u> Fax No. <u>423-265-3711</u> eMail Address <u>p_kushman@comcast.net</u> Contact Person's Name <u>PATRICK L. KUSHMAN</u> Estimated Delivery <u>ANYTIME-REG BUSINESS HOURS 7:00AM-5:00PM</u> Minority-Owned Business _____ Small Business _____ Veteran _____ Minority Woman-Owned Business _____ Disabled Veteran _____ Woman-Owned Business _____ **** ALL ITEMS MUST BE QUOTED F.O.B. DESTINATION ****					

**NOTE: ALL BIDS RECEIVED ARE SUBJECT TO THE TERMS AND CONDITIONS**

The City is Exempt from all Federal and State Tax.  
 Bids will be received at the above mentioned address.

TERMS OF PAYMENT: NET 30  
 TELEPHONE NUMBER: 423-266-8237

ALL BIDS MUST BE SIGNED – The undersigned offers the above quoted prices under the conditions contained herein.

COMPANY: RAMSEY TRUCKING, INC.  
 SIGNATURE: *Patrick L. Kushman*  
 NAME AND TITLE: OPERATIONS MANAGER

# BID SOLICITATION



City of Chattanooga  
 101 East 11th Street, Suite G13  
 Chattanooga, TN 37402

**BID OPENING DATE AND TIME:**  
 25-MAY-18 at 2:00 PM

**BID NUMBER:** 304999

**BUYER:**  
**PHONE #:** (423) 643-7230  
**DELIVERY REQUIRED:**

**SEALED BIDS**

Mail or submit two (2) signed copies of bid form to this office in the enclosed envelope. Retain one copy for your file.

V  
E  
N  
D  
O  
R

RFQ

M  
A  
I  
L  
T  
O

City of Chattanooga  
 101 East 11th Street, Suite G13  
 Chattanooga, TN 37402

Item	Class-Item	Quantity	Unit	Unit Price	Total
1	River Sand - Picked Up - Per Ton	450	Ton	<u>33.00</u>	
2	River Sand - Delivered - Per Ton	450	Ton	<u>35.00</u>	

**NOTE: ALL BIDS RECEIVED ARE SUBJECT TO THE TERMS AND CONDITIONS**

The City is Exempt from all Federal and State Tax.  
 Bids will be received at the above mentioned address.

TERMS OF PAYMENT: NET 30

TELEPHONE NUMBER: 423-266-8237

ALL BIDS MUST BE SIGNED – The undersigned offers the above quoted prices under the conditions contained herein.

COMPANY: RAMSEY TRUCKING, INC.

SIGNATURE: *Patrick L. Kushman*

NAME AND TITLE: PATRICK L. KUSHMAN  
 OPERATIONS MANAGER

Chapter No. 817 (HB0261/SB0377). "Iran Divestment Act" enacted.  
Vendor Disclosure and Acknowledgement

By submission of this bid, each bidder and each person signing on behalf of any bidder certifies, and in the case of a joint bid each party thereto certifies as to its own organization, under penalty of perjury, that to the best of its knowledge and belief that each bidder is not on the list created pursuant to § 12-12-106.

(SIGNED)



(PRINTED NAME)

PATRICK L. KUSHMAN

(BUSINESS NAME)

RAMSEY TRUCKING, INC.

(DATE)

05-22-18

For further information, please see website:

[https://www.tn.gov/assets/entities/generalservices/cpo/attachments/List\\_of\\_persons\\_pursuant\\_to\\_Tenn.\\_Code\\_Ann.\\_12-12-106,\\_Iran\\_Divestment\\_Act-July.pdf](https://www.tn.gov/assets/entities/generalservices/cpo/attachments/List_of_persons_pursuant_to_Tenn._Code_Ann._12-12-106,_Iran_Divestment_Act-July.pdf)

## Affirmative Action Plan

The City of Chattanooga is an equal opportunity employer and during the performance of this Contract, the Contractor agrees to abide by the equal opportunity goals of the City of Chattanooga as follows:

1. The Contractor will not discriminate against any employee or applicant for employment because of race, color, religion, sex, national origin, or handicap. The Contractor will take affirmative action to ensure that applicants are employed, and the employees are treated during employment without regard to their race, color, religion, sex, national origin, or handicap. Such action shall include, but not be limited to, the following: employment, upgrading, demotion, or transfer, recruitment or recruitment advertising, layoff or termination, rates of pay, or other forms of compensation, and selection for training, including apprenticeship. The Contractor agrees to post in conspicuous places, available to employees and applicants for employment, notices setting forth the provisions of this nondiscrimination clause.
2. The Contractor will, in all solicitations or advertisements for employees placed by or on behalf of the Contractor, state that all qualified applicants will receive consideration for employment without regard to race, color, religion, sex, national origin, or handicap.
3. The Contractor will send to each labor union or representative of workers with which he/she has a collective bargaining agreement or other contract or understanding, a notice advising the said labor union or workers' representatives of the Contractor's commitments under this section, and shall post copies of the notice in conspicuous places available to employees and applicants for employment.
4. In all construction contracts or subcontracts in excess of \$10,000 to be performed for the City of Chattanooga, any contractor and/or subcontractor is further required to file in duplicate within ten (10) days of being notified that it is the lowest responsible bidder, an affirmative action plan with the EEO Director of the City of Chattanooga. This plan shall state the Contractor's goals for minority and women utilization as a percentage of the work force on this project.
5. This Plan or any attachments thereto shall further provide a list of all employees annotated by job function, race, and sex who are expected to be utilized on this project. This plan or attachment thereto shall further describe the methods by which the Contractor or Subcontractor will utilize to make good faith efforts at providing employment opportunities for minorities and women.

During the term of this contract, the Contractor upon request of the City, will make available for inspection by the City of Chattanooga copies of payroll records, personnel documents and similar records or documents that may be used to verify the Contractor's compliance with these Equal Opportunity provisions.

- 6 The Contractor will include the portion of the sentence immediately preceding paragraph 1 and the provisions of paragraphs 1 through 6 in every subcontract so that such provisions will be requested of each subcontractor. The Contractor agrees to notify the City of Chattanooga of any subcontractor who refuses or fails to comply with these equal opportunity provisions. Any failure or refusal to comply with these provisions the Contractor and/or Subcontractor shall be a breach of this contract.



\_\_\_\_\_  
(Signature of Contractor)

**OPERATIONS - RAMSEY TRUCKING, INC.**

\_\_\_\_\_  
(Title and Name of Construction Company)

**05-22-18**

\_\_\_\_\_  
(Date)



# City of Chattanooga

Mayor Andy Berke

May 30, 2018

Mr. Justin Holland  
Administrator, Public Works Department  
Waste Resource Division  
1250 Market Street, Suite 2100  
Chattanooga, TN 37402

**Subject: Contract Renewal of Blanket PO No. 543612 – Comet Vehicle Tracking System – Fleet Management Division – Public Works Department**

Dear Mr. Holland:

Council approval is recommended to renew Blanket PO No. 543612 for Comet Vehicle Tracking System, Fleet Management Division, Public Works Department. The City of Chattanooga is renewing the first (1<sup>st</sup>) renewal option for twelve (12) months through May, 2019, with one (1) renewal option remaining for an estimated annual amount of \$125,000. A copy of the signed letter from vendor, and a copy of the contract is enclosed.

TCA 6-56-304.2 allows this single source blanket contract exempted from the usual advertising and bidding requirements. Attached are the letters from Actsoft, Inc. Bid is retained on file in the Purchasing Office for your review upon request.

I recommend renewing Blanket PO No. 543612 for Comet Vehicle Tracking System to Actsoft, Inc, 10006 N. Dale Mabry Highway, Suite 100, Tampa, FL 33618.

Respectfully yours,

Bonnie Woodward  
Director of Purchasing

BW/mlm

Attachments





**Mark L. McKeel, Buyer**



**101 East 11th Street, Suite G13**

**Chattanooga, TN 37402**

**Phone No.: 423-643-7236**

Dear Mr. McKeel,

This letter is to confirm that the Actsoft Comet Suite of products is a sole source product, developed, licensed and distributed exclusively by Actsoft Inc.

As such, Actsoft Inc. is the only firm that can provide the following in it's entirety:

- 1.) Provide implementation, servicing, activation and warranty of devices.
- 2.) Provide training and support for the Comet Suite of Actsoft products and equipment.
- 3.) Implement devices on pre-existing Comet Tracker software platform used today by the City of Chattanooga.
- 4.) There is no other like item or product available for purchase that would serve the same purpose or function in conjunction with the pre-existing software platform.
- 5.) Provide competitive rate and bill directly for all Actsoft services, data services, equipment, and implementation of project.

If you desire additional information, please do not hesitate to contact me at the phone or email address listed below.

Sincerely,

Drew Bickers

**National Director of Sales**

10006 N. Dale Mabry Hwy, Ste. 100 | Tampa, FL 33618

C: (678) 471-6547 | F: (813) 936-7541



# Purchase Order BLANKET



**City of Chattanooga**  
101 East 11th Street, Suite G13  
Chattanooga, TN 37402

<b>V E N D O R</b>	Vendor Number: Vendor Alternate ID: 26846  Actsoft Inc 10006 N Dale Mabry Hwy Ste 100 Tampa, FL 33618
--	--

PO Date: 22-MAY-17 Buyer: Mark McKeel FOB: DESTINATION Terms: Immediate	Purchase Order Number <b>543612</b>  INVOICES: Direct invoices in DUPLICATE to the Invoice address shown below.
--	--

<b>S H I P T O</b>	
--	--

<b>I N V O I C E</b>	Accounts Payable Division City of Chattanooga 101 East 11th Street, Suite 101 Chattanooga, TN 37402
--	--

Requestor		Requisition Number		Bid Number	
Line Nbr	Item ID - Item Description	Quantity	Unit	Unit Price	Total
Requisition / Bid No.: 152560 / 304704 Ordering Dept.: Fleet Management & City Wide Services Buyer: Mark McKeel Phone No.: 423-643-7236  Items Being Purchased: Vehicle Tracking System  ATTACHMENTS: City of Chattanooga (COC) Terms and Conditions posted on Website <a href="http://www.chattanooga.gov/purchasing/standard-terms-and-conditions">http://www.chattanooga.gov/purchasing/standard-terms-and-conditions</a> If you can't download call buyer for a copy.  This Shall Be A Twelve (12) Month Blanket Contract To Supply Vehicle Tracking Software and Accessories for Fleet Management and City Wide Services Vehicles.  The Contract Term May Be Renewed For An Additional Two (2) Twelve (12) Month Term Under The Same Terms And Conditions By Mutual Agreement. The City Of Chattanooga And The Contractor May Bilaterally Extend The Contract By Providing Written Confirmation Of Agreement By Both Parties At Least 30 Days Prior To The Contract's Current Expiration Date Into Any Successive Term As Provided Herein.  ***** Vendor Shall Hold Prices Firm for First (1st) Year of Contract *****  Price Escalation Clause: If as a result of a general change in prices or discounts, the Contractor has changed prices to all of its customers, the price under this contract may be adjusted accordingly. Contractor may be requested to show proof of alleged price changes prior to approval of any price adjustments.					

\*\*\*\*\* NOTICE \*\*\*\*\*

This Purchase Order ("Agreement") is a binding agreement between the City of Chattanooga and the Vendor. This Purchase Order shall be governed by the following documents: (1) Purchase Order; (2) City of Chattanooga Purchase Order Standard Terms and Conditions; (3) Vendor's response to the bid or quotation; and (4) terms and conditions set forth in the bid or quotation, each of which is hereby incorporated herein by reference and becomes a part of this Agreement. In the event any conflict of terms arises, the terms controlling the Agreement shall be in the order provided hereinabove. This Purchase Order is valid only when signed or electronically approved by the Finance Officer.

Electronic approval is on record in the purchasing information system which asserts that unencumbered appropriation is available to meet the expenditure covered by this Purchase Order; and further authorizes payment upon proper certification of receipt of goods and/or services.

# Purchase Order BLANKET



**City of Chattanooga**  
101 East 11th Street, Suite G13  
Chattanooga, TN 37402

<b>V E N D O R</b>	Vendor Number: Vendor Alternate ID: 26846  <b>Actsoft Inc</b> 10006 N Dale Mabry Hwy Ste 100 Tampa, FL 33618
--	---

PO Date: 22-MAY-17 Buyer: Mark McKeel FOB: DESTINATION Terms: Immediate
--

Purchase Order Number <b>543612</b>  INVOICES: Direct invoices in DUPLICATE to the invoice address shown below.
--

<b>S H I P T O</b>	
--	--

<b>I N V O I C E</b>	Accounts Payable Division City of Chattanooga 101 East 11th Street, Suite 101 Chattanooga, TN 37402
--	--

Requestor	Requisition Number	Bid Number																																																																		
<table border="1" style="width: 100%; border-collapse: collapse;"> <thead> <tr> <th style="width: 10%;">Line Nbr</th> <th style="width: 40%;">Item ID - Item Description</th> <th style="width: 10%;">Quantity</th> <th style="width: 10%;">Unit</th> <th style="width: 10%;">Unit Price</th> <th style="width: 10%;">Total</th> </tr> </thead> <tr> <td colspan="6">                             QUANTITIES ARE ESTIMATES ONLY THE CITY OF CHATTANOOGA SHALL GUARANTEE NO MINIMUM OR MAXIMUM AMOUNT PURCHASED DURING THE LIFETIME OF THE CONTRACT.                         </td> </tr> <tr> <td colspan="6">                             Purchase Order issued in accordance with Actsoft, Inc. bid received on MAY 2, 2017 is hereby made part of this contract.                         </td> </tr> <tr> <td colspan="6">                             City Council approved on May, 16, 2017.                         </td> </tr> <tr> <td colspan="6">                             Contract dates: May 22, 2017 to May 21, 2018                         </td> </tr> <tr> <td colspan="6"> <table style="width: 100%;"> <tr> <td style="width: 50%;">                                     Vendor Contact: Norman Schafer Phone No.: 704-649-9536 Fax No.: 813-936-7541 E-mail: nschafer@actsoft.com                                 </td> <td style="width: 50%;">                                     Kevin Thigpen Phone No.: 813-936-2331 Fax No.: 813-936-7541 E-mail: newagreements@actsoft.com                                 </td> </tr> </table> </td> </tr> <tr> <td colspan="6">                             The undersigned hereby agrees to perform the services in accordance with the terms and conditions as set forth in this Purchase Order, the City of Chattanooga Standard Terms &amp; Conditions, and the bid or quotation.                         </td> </tr> <tr> <td colspan="2">                             Representative: <u>Cathy Chauvette</u> </td> <td colspan="4">                             Agreed to and accepted by:                         </td> </tr> <tr> <td colspan="2">                             Title: <u>Controller</u> </td> <td colspan="4">                             CITY OF CHATTANOOGA, TENNESSEE                         </td> </tr> <tr> <td colspan="2">                             Date: <u>5-22-17</u> </td> <td colspan="4">                             Name/Title: <u>Mark McKeel, Buyer</u> </td> </tr> <tr> <td colspan="2"> </td> <td colspan="4">                             Department: <u>PURCHASING</u> </td> </tr> </table>	Line Nbr	Item ID - Item Description	Quantity	Unit	Unit Price	Total	QUANTITIES ARE ESTIMATES ONLY THE CITY OF CHATTANOOGA SHALL GUARANTEE NO MINIMUM OR MAXIMUM AMOUNT PURCHASED DURING THE LIFETIME OF THE CONTRACT.						Purchase Order issued in accordance with Actsoft, Inc. bid received on MAY 2, 2017 is hereby made part of this contract.						City Council approved on May, 16, 2017.						Contract dates: May 22, 2017 to May 21, 2018						<table style="width: 100%;"> <tr> <td style="width: 50%;">                                     Vendor Contact: Norman Schafer Phone No.: 704-649-9536 Fax No.: 813-936-7541 E-mail: nschafer@actsoft.com                                 </td> <td style="width: 50%;">                                     Kevin Thigpen Phone No.: 813-936-2331 Fax No.: 813-936-7541 E-mail: newagreements@actsoft.com                                 </td> </tr> </table>						Vendor Contact: Norman Schafer Phone No.: 704-649-9536 Fax No.: 813-936-7541 E-mail: nschafer@actsoft.com	Kevin Thigpen Phone No.: 813-936-2331 Fax No.: 813-936-7541 E-mail: newagreements@actsoft.com	The undersigned hereby agrees to perform the services in accordance with the terms and conditions as set forth in this Purchase Order, the City of Chattanooga Standard Terms & Conditions, and the bid or quotation.						Representative: <u>Cathy Chauvette</u>		Agreed to and accepted by:				Title: <u>Controller</u>		CITY OF CHATTANOOGA, TENNESSEE				Date: <u>5-22-17</u>		Name/Title: <u>Mark McKeel, Buyer</u>						Department: <u>PURCHASING</u>			
Line Nbr	Item ID - Item Description	Quantity	Unit	Unit Price	Total																																																															
QUANTITIES ARE ESTIMATES ONLY THE CITY OF CHATTANOOGA SHALL GUARANTEE NO MINIMUM OR MAXIMUM AMOUNT PURCHASED DURING THE LIFETIME OF THE CONTRACT.																																																																				
Purchase Order issued in accordance with Actsoft, Inc. bid received on MAY 2, 2017 is hereby made part of this contract.																																																																				
City Council approved on May, 16, 2017.																																																																				
Contract dates: May 22, 2017 to May 21, 2018																																																																				
<table style="width: 100%;"> <tr> <td style="width: 50%;">                                     Vendor Contact: Norman Schafer Phone No.: 704-649-9536 Fax No.: 813-936-7541 E-mail: nschafer@actsoft.com                                 </td> <td style="width: 50%;">                                     Kevin Thigpen Phone No.: 813-936-2331 Fax No.: 813-936-7541 E-mail: newagreements@actsoft.com                                 </td> </tr> </table>						Vendor Contact: Norman Schafer Phone No.: 704-649-9536 Fax No.: 813-936-7541 E-mail: nschafer@actsoft.com	Kevin Thigpen Phone No.: 813-936-2331 Fax No.: 813-936-7541 E-mail: newagreements@actsoft.com																																																													
Vendor Contact: Norman Schafer Phone No.: 704-649-9536 Fax No.: 813-936-7541 E-mail: nschafer@actsoft.com	Kevin Thigpen Phone No.: 813-936-2331 Fax No.: 813-936-7541 E-mail: newagreements@actsoft.com																																																																			
The undersigned hereby agrees to perform the services in accordance with the terms and conditions as set forth in this Purchase Order, the City of Chattanooga Standard Terms & Conditions, and the bid or quotation.																																																																				
Representative: <u>Cathy Chauvette</u>		Agreed to and accepted by:																																																																		
Title: <u>Controller</u>		CITY OF CHATTANOOGA, TENNESSEE																																																																		
Date: <u>5-22-17</u>		Name/Title: <u>Mark McKeel, Buyer</u>																																																																		
		Department: <u>PURCHASING</u>																																																																		

  |  |

\*\*\*\*\* NOTICE \*\*\*\*\*

This Purchase Order ("Agreement") is a binding agreement between the City of Chattanooga and the Vendor. This Purchase Order shall be governed by the following documents: (1) Purchase Order; (2) City of Chattanooga Purchase Order Standard Terms and Conditions; (3) Vendor's response to the bid or quotation; and (4) terms and conditions set forth in the bid or quotation. Each of which is hereby incorporated herein by reference and becomes a part of this Agreement. In the event any conflict of terms arises, the terms controlling the Agreement shall be in the order provided heretobove. This Purchase Order is valid only when signed or electronically approved by the Finance Officer.

Electronic approval is on record in the purchasing information system which asserts that unencumbered appropriation is available to meet the expenditure covered by this Purchase Order; and further authorizes payment upon proper certification of receipt of goods and/or services.

# Purchase Order BLANKET



**City of Chattanooga**  
101 East 11th Street, Suite G13  
Chattanooga, TN 37402

<b>V E N D O R</b>	Vendor Number: Vendor Alternate ID: 26846  Actsoft Inc 10006 N Dale Mabry Hwy Ste 100 Tampa, FL 33618
--	--

PO Date: 22-MAY-17 Buyer: Mark McKeel FOB: DESTINATION Terms: Immediate	<b>Purchase Order Number 543612</b>  INVOICES: Direct invoices in DUPLICATE to the Invoice address shown below.
--	---

<b>S H I P T O</b>	
--	--

<b>I N V O I C E</b>	Accounts Payable Division City of Chattanooga 101 East 11th Street, Suite 101 Chattanooga, TN 37402
--	--

Requestor			Requisition Number		Bid Number
Line Nbr	Item ID - Item Description	Quantity	Unit	Unit Price	Total
1	Comet Tracker Software with Data (201+ Unit)	0.00	Month	\$ 17.0000	\$ 0.00
2	Comet Tracker Software with Data (101 - 200 Units)	0.00	Month	\$ 17.0000	\$ 0.00
3	Comet Tracker Software with Data (1 - 100 Units)	0.00	Month	\$ 17.0000	\$ 0.00
4	Software License Fee (One Time per Unit)	0.00	Each	\$ 20.0000	\$ 0.00
5	CalAmp LMU26C4V0-G1000, Requires Harness	0.00	Each	\$ 199.0000	\$ 0.00
6	Power Harness 5C848-8 Wiring Harness for 3-Wire Install	0.00	Each	\$ 9.9900	\$ 0.00
7	Power Harness 5C908 Wiring Harness for 3-Wire Plus Event Wiring/PTO	0.00	Each	\$ 9.9900	\$ 0.00
8	CalAmp LMU30C40V0-G1000, Does Not Require Harness	0.00	Each	\$ 199.0000	\$ 0.00
9	Entire Catalog; Net (0%)	0.00	Each	\$ 1.0000	\$ 0.00
10	Shipping (per Order of 20 Units)	0.00	Each	\$ 19.9900	\$ 0.00

**TOTAL: \$ .00**

\*\*\*\*\* NOTICE \*\*\*\*\*

This Purchase Order ("Agreement") is a binding agreement between the City of Chattanooga and the Vendor. This Purchase Order shall be governed by the following documents: (1) Purchase Order; (2) City of Chattanooga Purchase Order Standard Terms and Conditions; (3) Vendor's response to the bid or quotation; and (4) terms and conditions set forth in the bid or quotation, each of which is hereby incorporated herein by reference and becomes a part of this Agreement. In the event any conflict of terms arises, the terms controlling the Agreement shall be in the order provided hereinabove. This Purchase Order is valid only when signed or electronically approved by the Finance Officer.

Electronic approval is on record in the purchasing information system which asserts that unencumbered appropriation is available to meet the expenditure covered by this Purchase Order; and further authorizes payment upon proper certification of receipt of goods and/or services.



**City of Chattanooga**  
**Mayor Andy Berke**

May 11, 2018

Actsoft, Inc  
Attn: Andrew King  
10006 N. Dale Mabry Highway, Suite 100  
Tampa, FL 33618

Subject: 543612 – Comet Vehicle Tracking System

Dear Mr. King:

The City of Chattanooga would like to extend the above referenced contract for an additional twelve (12) months at the same contracted price(s).

The new expiration date will be May 21, 2019.

Please render the appropriate signature below and return via fax to 423-643-7244 or by email to [mmckeel@chattanooga.gov](mailto:mmckeel@chattanooga.gov) if you agree to renewal.

As always, we appreciate the good service you have rendered in the past, and we look forward to working with you in the future.

Signed:  Date: 5/24/2018

Sincerely,



Mark McKeel, Buyer  
City of Chattanooga  
Phone: (423) 643-7236 Fax: (423) 643-7244



# City of Chattanooga

Mayor Andy Berke

May 29, 2018

Mr. Blythe Bailey  
Administrator  
Transportation Department  
1250 Market Street, Suite 3000  
Chattanooga TN, 37402

Subject: Contract Renewal of Blanket 544594 – Pedestrian Street Light Poles –  
Transportation Department

Dear Mr. Bailey:

Council approval is recommended to renew blanket contract 544594 for Pedestrian Street Light Poles as needed by the Transportation Department. The City of Chattanooga is exercising the option to renew this contract for an additional twelve (12) months through July, 2019. The estimated annual expenditure under this contract is \$95,250.00.

The award of this blanket contract was originally approved by City Council on July, 11, 2017. The invitation to bid was sent to three (3) vendors as well as formally advertised. Two (2) responses were received. The bids are retained in the Purchasing Office for review upon request. A copy of Blanket Contract 544594 is attached.

I recommend renewing this blanket contract with Sun Valley, 660 West Avenue O, Palmdale, CA 93551, as being in the best interests of the City of Chattanooga.

Respectfully yours,

Bonnie Woodward  
Purchasing Director

BW/dp  
Attachments



# City of Chattanooga

Mayor Andy Berke

May 22, 2018

Sun Valley  
Attn: Yenia Lopez  
660 West Ave O  
Palmdale, CA 93551

**Subject: 544594 - Renewal For Pedestrian Street Light Poles – Transportation Department**

Dear Ms. Lopez:

The City of Chattanooga Transportation Department would like to have an extension of this contract for an additional (12) twelve month term under the same terms and conditions.

By mutual agreement, the extended contract date will be July 16, 2019. Please sign below and return by fax if you are in agreement with the contract renewal.

As always, we appreciate the quality of service you have provided and look forward to working with you in the future.

Signed:



---

Dedra Partridge – Buyer  
City of Chattanooga/Purchasing  
101 East 11<sup>th</sup> Street City Hall, G 13  
Chattanooga, TN 37402

Tele: (423) 643-7237

Fax: (423) 643-7244

dpartridge@chattanooga.gov

# Purchase Order BLANKET



**City of Chattanooga**  
101 East 11th Street, Suite G13  
Chattanooga, TN 37402

<b>V E N D O R</b>	Vendor Number: 744246 Vendor Alternate ID: 1118  Sun Valley 660 West Ave O Palmdale, CA 93551
--	--

PO Date: 18-JUL-17 Buyer: Dedra Partridge FOB: DESTINATION Terms: Immediate	<b>Purchase Order Number 544594</b>  INVOICES: Direct invoices in DUPLICATE to the Invoice address shown below.
--	---

<b>S H I P T O</b>	
--	--

<b>I N V O I C E</b>	Accounts Payable Division City of Chattanooga 101 East 11th Street, Suite 101 Chattanooga, TN 37402
--	--

Requestor		Requisition Number		Bid Number	
<b>Line Nbr</b>	<b>Item ID - Item Description</b>	<b>Quantity</b>	<b>Unit</b>	<b>Unit Price</b>	<b>Total</b>
Requisition No.: 153737 Ordering Dept.: Transportation Department Buyer: Dedra Partridge Phone No.: (423) 643-7237  Items Being Purchased: Pedestrian Street Light Poles  This Shall Be A Twelve (12) Month Blanket Contract To Supply Pedestrian Street Light Poles. The Contract Term May Be Renewed For Two (2) Additional Twelve (12) Month Term Under The Same Terms And Conditions By Mutual Agreement. The City Of Chattanooga And The Contractor May Bilaterally Extend The Contract By Providing Written Confirmation Of Agreement By Both Parties At Least 30 Days Prior To The Contract's Current Expiration Date Into Any Successive Term As Provided Herein.  Vendor Contact: Yenia Lopez (661) 233-2048 (661) 233-2001 (fax) yenial@usaltg.com  City Contact: Greg Herold (423) 643-5968 gherold@chattanooga.gov  Contract Term: July 18, 2017 thru July 17, 2018  Approved By City Council On July 11, 2017					

B. Woodward  
 7/18/17

\*\*\*\*\* NOTICE \*\*\*\*\*

This Purchase Order ("Agreement") is a binding agreement between the City of Chattanooga and the Vendor. This Purchase Order shall be governed by the following documents: (1) Purchase Order; (2) City of Chattanooga Purchase Order Standard Terms and Conditions; (3) Vendor's response to the bid or quotation; and (4) terms and conditions set forth in the bid or quotation, each of which is hereby incorporated herein by reference and becomes a part of this Agreement. In the event any conflict of terms arises, the terms controlling the Agreement shall be in the order provided hereinabove. This Purchase Order is valid only when signed or electronically approved by the Finance Officer.

Electronic approval is on record in the purchasing information system which asserts that unencumbered appropriation is available to meet the expenditure covered by this Purchase Order; and further authorizes payment upon proper certification of receipt of goods and/or services.



# Purchase Order BLANKET



**City of Chattanooga**  
101 East 11th Street, Suite G13  
Chattanooga, TN 37402

<b>V E N D O R</b>	Vendor Number: 744246 Vendor Alternate ID: 1118  Sun Valley 660 West Ave O Palmdale, CA 93551
--	--

PO Date: 18-JUL-17 Buyer: Dedra Partridge FOB: DESTINATION Terms: Immediate	<b>Purchase Order Number 544594</b>  INVOICES: Direct invoices in DUPLICATE to the Invoice address shown below.
--	---

<b>S H I P T O</b>	
--	--

<b>I N V O I C E</b>	Accounts Payable Division City of Chattanooga 101 East 11th Street, Suite 101 Chattanooga, TN 37402
--	--

Requestor			Requisition Number		Bid Number
Line Nbr	Item ID - Item Description	Quantity	Unit	Unit Price	Total
1	Street Light Poles Octagonal	0.00	Each	\$ 615.0000	\$ 0.00
2	Street Light Poles Modern style	0.00	Each	\$ 675.0000	\$ 0.00

**TOTAL: \$ .00**

\*\*\*\*\* NOTICE \*\*\*\*\*

This Purchase Order ("Agreement") is a binding agreement between the City of Chattanooga and the Vendor. This Purchase Order shall be governed by the following documents: (1) Purchase Order; (2) City of Chattanooga Purchase Order Standard Terms and Conditions; (3) Vendor's response to the bid or quotation; and (4) terms and conditions set forth in the bid or quotation, each of which is hereby incorporated herein by reference and becomes a part of this Agreement. In the event any conflict of terms arises, the terms controlling the Agreement shall be in the order provided hereinabove. This Purchase Order is valid only when signed or electronically approved by the Finance Officer.

Electronic approval is on record in the purchasing information system which asserts that unencumbered appropriation is available to meet the expenditure covered by this Purchase Order; and further authorizes payment upon proper certification of receipt of goods and/or services.



# City of Chattanooga

Mayor Andy Berke

May 24, 2018

Lurone Jennings, Administrator  
Department of Youth and Family Development  
501 West 12th Street  
Chattanooga, TN 37402

Subject: R132858 – Extend Blanket Contract 543901 for Baby Diapers and Wipes

Dear Mr. Jennings:

Council approval is recommended to extend blanket contract 543901 for Baby Diapers and Wipes as needed by the Department of Youth and Family Development for an additional year upon the same terms. The estimated annual expenditure is \$135,000.00.

The bid solicitation was sent to ten (10) vendors. Seven (7) bids were received. Bids are available in the Purchasing Office for your review upon request. A copy of blanket contract 543901 is attached.

I recommend the extension of this blanket contract with Diapers4Less, as being in the best interest for the City of Chattanooga.

Respectfully yours,

Bonnie Woodward  
Purchasing Director

BW/wt  
Attachment

Vendor address:

Diapers4Less  
13460 60<sup>th</sup> Place N., Suite 110  
Plymouth, MN 55446

# Purchase Order BLANKET



**City of Chattanooga**  
101 East 11th Street, Suite G13  
Chattanooga, TN 37402

<b>V E N D O R</b>	Vendor Number: Vendor Alternate ID: 263083  Diapers 4 Less Inc 13460 60th Place North Unit 110 Plymouth, MN 55446
--	--

PO Date: 06-JUN-17 Buyer: William Tucker FOB: DESTINATION Terms: Immediate
---

<b>Purchase Order Number 543901</b>
INVOICES: Direct invoices in DUPLICATE to the Invoice address shown below.

<b>S H I P T O</b>	
--	--

<b>I N V O I C E</b>	Accounts Payable Division City of Chattanooga 101 East 11th Street, Suite 101 Chattanooga, TN 37402
--	--

Requestor		Requisition Number		Bid Number	
<b>Line Nbr</b>	<b>Item ID - Item Description</b>	<b>Quantity</b>	<b>Unit</b>	<b>Unit Price</b>	<b>Total</b>
Requisition No: 150776 Ordering Dept: Youth and Family Development Buyer: William Tucker Fax: 423-643-7244 Email: wtucker@chattanooga.gov ***** Items Being Purchased: Baby Diapers and Wipes ***** This shall be a twelve-month blanket contract to supply Baby Diapers and Wipes as needed by agencies of the City of Chattanooga. The contract terms may be renewed for two (2) additional twelve (12)-month terms under the same terms and conditions by mutual agreement. The City of Chattanooga and the Contractor may extend the contract by providing written confirmation of agreement by both parties at least 30 days prior to the contract's current expiration date. ***** Items being purchased are to be delivered to:  Various Head Start and Early Head Start Centers as managed by  Department of Youth and Family Development 501 West 12th Street Chattanooga, TN 37402  Delivery Contact: Chris Brown, Tel. 423-643-6400 ***** Approved by City Council 5-30-17 Contract Start Date 6-6-17 Initial Ending Date: 6-5-18 ***** The City of Chattanooga Standard Terms and Conditions are incorporated herein by reference ***** Vendor Contact Information:  Vendor Name: Diapers4Less, Inc. Contact Person: Cindy Cox Tel.: 800-270-1816 Fax: 866-924-2991 Email: sales@diapers-4-less.com Mailing Address: 13460 60th Place N, #110 City, State, Zip: Plymouth, MN 55446 *****					

This Purchase Order ("Agreement") is a binding agreement between the City of Chattanooga and the Vendor. This Purchase Order shall be governed by the following documents: (1) Purchase Order; (2) City of Chattanooga Purchase Order Standard Terms and Conditions; (3) Vendor's response to the bid or quotation; and (4) terms and conditions set forth in the bid or quotation, each of which is hereby incorporated herein by reference and becomes a part of this Agreement. In the event any conflict of terms arises, the terms controlling the Agreement shall be in the order provided hereinabove. This Purchase Order is valid only when signed or electronically approved by the Finance Officer.

Electronic approval is on record in the purchasing information system which asserts that unencumbered appropriation is available to meet the expenditure covered by this Purchase Order; and further authorizes payment upon proper certification of receipt of goods and/or services.

# Purchase Order BLANKET

Page 2 of 4  
Printed: 06/06/2017



**City of Chattanooga**  
101 East 11th Street, Suite G13  
Chattanooga, TN 37402

<b>V E N D O R</b>	Vendor Number: Vendor Alternate ID: 263083  Diapers 4 Less Inc 13460 60th Place North Unit 110 Plymouth, MN 55446
--	--

PO Date: 06-JUN-17 Buyer: William Tucker FOB: DESTINATION Terms: Immediate	<b>Purchase Order Number 543901</b>  <b>INVOICES: Direct invoices in DUPLICATE to the Invoice address shown below.</b>
---	--

<b>S H I P T O</b>	
--	--

<b>I N V O I C E</b>	Accounts Payable Division City of Chattanooga 101 East 11th Street, Suite 101 Chattanooga, TN 37402
--	--

Requestor			Requisition Number		Bid Number
Line Nbr	Item ID - Item Description	Quantity	Unit	Unit Price	Total
1	Diapers Size 1 - Small (8-14lbs)Quantity 120 per case	0.00	Case	\$ 52.9500	\$ 0.00
2	Diapers Size 2 - Sm-Med (12-18)Quantity 120 per case	0.00	Case	\$ 52.9500	\$ 0.00
3	Diapers Size 3 - Med(16-28lbs)Quantity 120 per case	0.00	Case	\$ 52.9500	\$ 0.00
4	Diapers Size 4 - Large(22-37lbs)Quantity 120 per case	0.00	Case	\$ 52.9500	\$ 0.00
5	Diapers Size 5 - Extra-Large(27+lbs)Quantity 120 per case	0.00	Case	\$ 52.9500	\$ 0.00
6	Diapers Size 6 - 2Extra-Large(37+lbs)Quantity 120 per case	0.00	Case	\$ 52.9500	\$ 0.00
7	Pull Ups Size 2T-3T (18-34lbs) 102 count per case for Boys	0.00	Case	\$ 39.9500	\$ 0.00
8	Pull Ups Size 3T-4T (32-40lbs) 92 count per case for Boys	0.00	Case	\$ 39.9500	\$ 0.00
9	Pull Ups Size 4T-5T (38+lbs) 78 count per case for Boys	0.00	Case	\$ 39.9500	\$ 0.00
10	Baby Wipes 900 Count per case.	0.00	Case	\$ 34.9500	\$ 0.00

\*\*\*\*\* NOTICE \*\*\*\*\*

This Purchase Order ("Agreement") is a binding agreement between the City of Chattanooga and the Vendor. This Purchase Order shall be governed by the following documents: (1) Purchase Order; (2) City of Chattanooga Purchase Order Standard Terms and Conditions; (3) Vendor's response to the bid or quotation, and (4) terms and conditions set forth in the bid or quotation, each of which is hereby incorporated herein by reference and becomes a part of this Agreement. In the event any conflict of terms arises, the terms controlling the Agreement shall be in the order provided hereinabove. This Purchase Order is valid only when signed or electronically approved by the Finance Officer.

Electronic approval is on record in the purchasing information system which asserts that unencumbered appropriation is available to meet the expenditure covered by this Purchase Order; and further authorizes payment upon proper certification of receipt of goods and/or services.

# Purchase Order BLANKET



**City of Chattanooga**  
101 East 11th Street, Suite G13  
Chattanooga, TN 37402

<b>V E N D O R</b>	Vendor Number: Vendor Alternate ID: 263083  Diapers 4 Less Inc 13460 60th Place North Unit 110 Plymouth, MN 55446
--	--

PO Date: 06-JUN-17 Buyer: William Tucker FOB: DESTINATION Terms: Immediate	<b>Purchase Order Number 543901</b>  INVOICES: Direct invoices in DUPLICATE to the Invoice address shown below.
---	---

<b>S H I P T O</b>	
--	--

<b>I N V O I C E</b>	Accounts Payable Division City of Chattanooga 101 East 11th Street, Suite 101 Chattanooga, TN 37402
--	--

Requestor			Requisition Number		Bid Number
Line Nbr	Item ID - Item Description	Quantity	Unit	Unit Price	Total
11	Pull Ups Size 2T-3T (18-34lbs) 102 count per case for Girls	0.00	Case	\$ 39.9500	\$ 0.00
12	Pull Ups Size 3T-4T (32-40lbs) 92 count per case for Girls	0.00	Case	\$ 39.9500	\$ 0.00
13	Pull Ups Size 4T-5T (38+lbs) 78 count per case for Girls	0.00	Case	\$ 39.9500	\$ 0.00

**TOTAL: \$ .00**

\*\*\*\*\* NOTICE \*\*\*\*\*

This Purchase Order ("Agreement") is a binding agreement between the City of Chattanooga and the Vendor. This Purchase Order shall be governed by the following documents: (1) Purchase Order; (2) City of Chattanooga Purchase Order Standard Terms and Conditions; (3) Vendor's response to the bid or quotation; and (4) terms and conditions set forth in the bid or quotation, each of which is hereby incorporated herein by reference and becomes a part of this Agreement. In the event any conflict of terms arises, the terms controlling the Agreement shall be in the order provided hereinabove. This Purchase Order is valid only when signed or electronically approved by the Finance Officer.

Electronic approval is on record in the purchasing information system which asserts that unencumbered appropriation is available to meet the expenditure covered by this Purchase Order; and further authorizes payment upon proper certification of receipt of goods and/or services.